

TRZ2

Turbine gas meters DN 50 – 150
for custody transfer

Applications

Gas measurement at low and high operating pressures

Brief information

Elster-Instromet TRZ2 turbine gas meters are robust meters for use in stationary conditions. Over years they have proved themselves to be highly accurate and reliable devices for measuring the flow of gaseous substances.

With the patented Elster-Instromet measuring cartridge it is possible to save service time by replacement of the cartridge on site.

The measuring cartridge is supported with O-rings, is free of tension and is, therefore, not affected by any influences stemming from the housing or the ambient conditions such as temperature fluctuations.

Principle

The gas flowing through the meter sets a turbine wheel in motion and the number of revolutions of the wheel is proportional to the passed volume. The gas entering the meter is accelerated by a special designed and patented flow straightener, located at the meter inlet. This flow straightener is designed in such a way that any potential flow disturbances such as swirl or asymmetric flow are eliminated. Because the flow velocity is increased, the driving impulse on the turbine wheel is also strengthened. This means that it is possible to achieve a high accuracy within the permissible error limits, even with low flow rates. The flow onto the turbine wheel is axial and the wheel is run on the main shaft with robust dimensioned ball bearings.

The revolution of the turbine wheel is reduced by a gear. Via a magnetic coupling, a transmission shaft drives the 8-digit mechanical roller counter located in the pressureless totalizer head. After the gas has passed the turbine wheel, a pressure recovery is achieved in the outlet channel, which is designed to create optimum flow conditions.

Conformity

Elster-Instromet TRZ2 meters are manufactured in accordance with DIN EN ISO 9001:2000 and DIN EN ISO 14001. They are designed, produced and tested in accordance with the following guidelines, standards and references:

- EC Directive 71/318/EC or directive 2004/22/EC (MID)
- EC Directive 97/23/EC concerning pressure equipment (PED)
- EC Directive 94/9/EC concerning explosion protection (ATEX)
- Applied European standards (et al. EN 12261)

All manufactured meters are tested by official, PTB approved test rigs. Test certificates in accordance with PED requirements are available for pressure and strength tests.

Material

The housings are made of GGG-40 (ductile iron) or steel. The meters meet the highest safety standards and are fire-proof (HTB).

* DN 50/2" without patented flow straightener (inlet pipe length $L > 5$ DN required)



Main features

- Turbine gas meters with measuring cartridge
- Aluminium flow straightener DN 80 – 150
- Meter types G 65 - G 1000
- Flow range 5 - 1600 m³/h
- Diameters DN 50* - 150 (2" - 6")
- Pressure rates
PN 10 – 100, ANSI 150 – 600
- Temperature ranges:
MID: -25 °C to +55 °C ($Q_{\min} \neq 8$ m³/h)
PED: -25 °C to +60 °C (steel)
ATEX: -20 °C to +60 °C
- Manual oil pump (standard for PN 25 – 100 and ANSI 300 – 600)
- Compact installation, inlet pipe length $L \geq 2$ DN
- Length 3 DN
- Thermowell built into meter housing (optional)
- Integrated HF-pulsar (optional)
- Absolute ENCODER S1 (option)
- EC, MID as well as different national approvals (e.g. PTB)
- Media: natural gas, petroleum gas, town gas, nitrogen, argon, further gases on request

S1 index (standard)

- 8-digit mechanical index
- Totalizer head can be rotated 350°
- Protection class IP67
- Absolute-ENCODER S1 (optional) useable as main meter index



Pulsers

Low-frequency (LF): Elster-Instromet TRZ2 turbine gas meters are fitted with two low-frequency pulsers and one switch for monitoring any attempts at manipulation (PCM). The low-frequency pulses, which are generated by Reed switches in the plug-in pulser IN-S1x, are used to transmit the actual volume in m³ to a volume corrector, for example. The maximum frequency is 0.5 Hz.

Standard version:

- IN-S10 with a 2.5m open-ended 6-wire cable.

Options:

- IN-S11 with a 6-pin flange plug and a connector socket.
- IN-S12 with two 6-pin flange plugs and two connector sockets.

High-frequency (HF) (optional): If higher pulse rates or a higher resolution is required for control or regulation purposes, the turbine meter can be equipped with high-frequency pulsers.

A special feature of the Elster-Instromet TRZ2 is the fact that there are two separate systems:

- A1S picks up the blades of the turbine wheel.
- A1R picks up reference boreholes in the turbine wheel.

Up to 4 high-frequency pulsers can be ordered for the individual meter models.

The plugs for the high-frequency pulsers are designed to save space. They are located at an angle on the side of the housing and can be rotated.

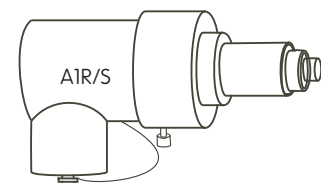
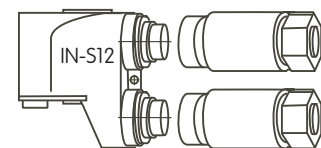
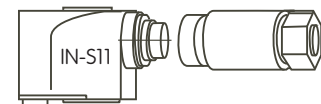
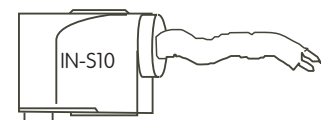

Absolute-ENCODER S1 (optional)

The Absolute-ENCODER S1 is a mechanical index, whereby the meter reading is optoelectronically scanned and transferred to the supplementary device via an electronic interface (e.g. EK260 and EK280 volume converter). Thus the Absolute-ENCODER index is an ideal combination of the advantages of mechanical and electronic indexes.

The procedure is certified by the German PTB.

The Absolute-ENCODER S1 does not require a power supply as the input is provided via the electrical interface of the supplementary device.

Available interface variations:
NAMUR, M-Bus and SCR

The Absolute-ENCODER S1 is also available as a clip-on index for a mechanical drive.



Accuracy

Limits

Typical error limits:

±0.5 % for 0.2 Q_{max} to Q_{max}

±1.0 % for Q_{min} to 0.2 Q_{max}

Maximum permissible error limits according to standard EN 12261:

±1.0 % for 0.2 Q_{max} to Q_{max}

±2.0 % for Q_{min} to 0.2 Q_{max}

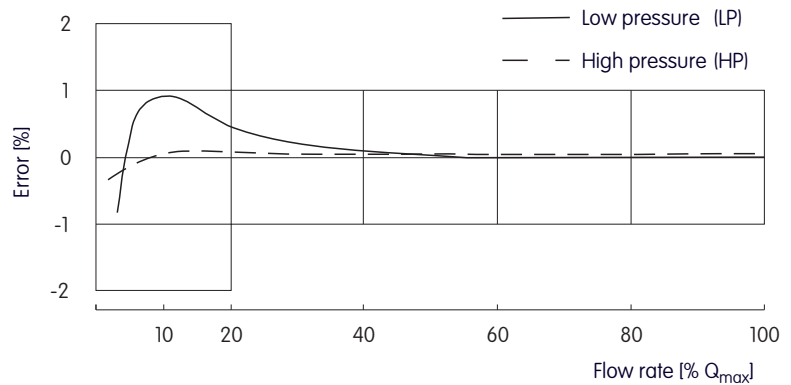

Measuring range

The low-pressure measuring range (atmospheric pressure) is 1:20 and optional 1:30 (see table with technical data).

When the actual pressure rises, the flow limit Q_{min} becomes lower because of the increasing motive energy. The effective measuring range is therefore larger. Q_{min, HP} is shown in the table on the right. It should be noted that the permissible measuring ranges are defined by national regulations.

Meter size	Q _{max} [m ³ /h]	Q _{min, LP} [m ³ /h]	Actual absolute pressure [bar]							
			5	10	15	20	25	30	35	40
			Q _{min, HP} [m ³ /h]							
G 65	100	5	3	2	2	1	1	1	1	1
G 100	160	8	4	3	3	2	2	2	2	2
G 160	250	13	7	5	4	4	3	3	3	3
G 250	400	20	11	8	6	6	5	5	4	4
G 400	650	32	17	12	10	9	8	7	7	6
G 650	1000	50	27	19	16	13	12	11	10	10
G 1000	1600	80	44	31	25	22	19	18	16	15

$$Q_{\min, HP} = Q_{\min, LP} \cdot \frac{1}{\sqrt{d_v \cdot p}}$$

d_v = density ratio of gas (natural gas d_v = 0.65)
p = actual absolute pressure [bar]

Pressure loss

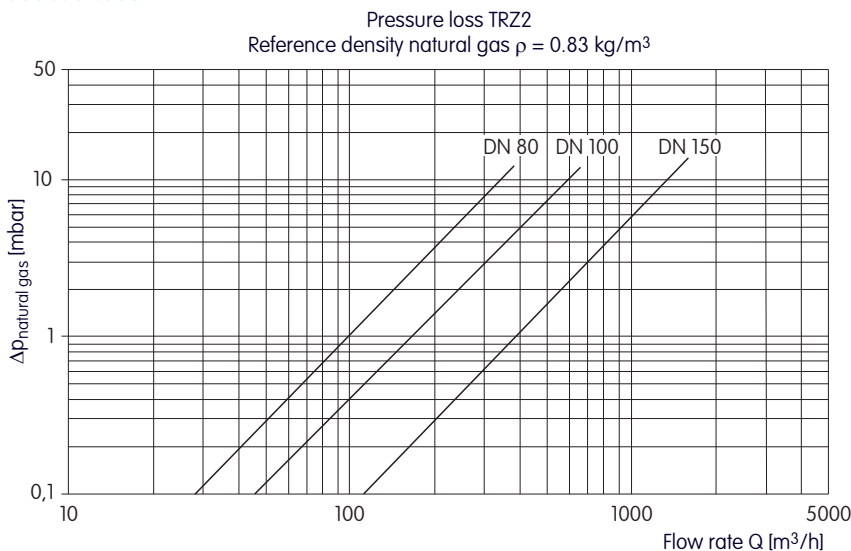

Pressure loss under operating conditions:

$$\Delta p_b = \Delta p_1 \cdot \rho_b$$

Density under operating conditions:

$$\rho_b = \rho_n \cdot \frac{p_b}{p_{atm}}$$

Pressure loss for any gas G:

$$\Delta p_G = \Delta p_{ng} \cdot \frac{\rho_G}{\rho_{ng}}$$

Sign	Description	Unit
ρ _b	Density in operating condition	kg/m ³
ρ _n	Density in standard condition	kg/m ³
ρ _G	Density of any gas	kg/m ³
ρ _{ng}	Density of natural gas	kg/m ³
p _{atm}	Absolute atmospheric pressure	bar

Sign	Description	Unit
p _b	Absolute operating pressure (overpressure)	kg/m ³
Δp ₁	Pressure loss for natural gas at 1 bar	kg/m ³
Δp _b	Pressure loss for natural gas at operating conditions	kg/m ³
Δp _{ng}	Pressure loss for natural gas	kg/m ³
Δp _G	Pressure loss for any gas	bar

Installation tips

Mounting position:

According to EN 12261 Elster-Instromet turbine gas meters can be operated in horizontal and vertical position.

Inlet pipe: ≥ 2 DN independent of flow disturbance for DN 80 – 150,
 ≥ 5 DN for DN 50

Outlet pipe: Fitting in nominal width of the meter

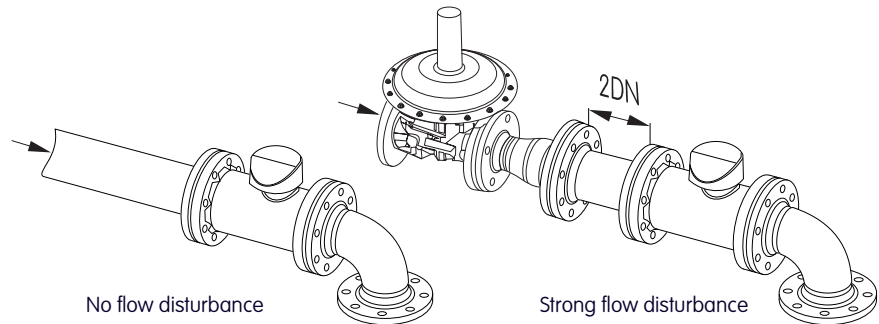

Technical data														
Measuring data	Diameter	DN	50	80	80	80	100	100	100	150	150	150	150	
	Meter size	G	65	100	160	250 *	160	250	400 *	250	400	650 *	1000 *	
	Measuring range	Q_{min}		5	8	13	20	13	20	32	20	32	50	80
		Q_{max}		100	160	250	400	250	400	650	400	650	1000	1600
	Δp ** at Q_{max}	[mbar]		11	2	5	12	2	5	13	1	2	6	15
Temperature range	-25 °C to + 55 °C ($Q_{min} \neq 8$ m ³ /h), -10 °C to +55 °C ($Q_{min} = 8$ m ³ /h)													
Temperature range	-25 °C to +60 °C (steel), -20 °C to +60 °C (GGG-40)													
Pressure rates	PN 10, 16, 25, 40, 64, 100 / ANSI 150, 300 , 600													
Housing ***	Dimensions	A mm	165	215	215	215	273	273	273	356	356	356	356	
		B mm	155	172	172	172	185	185	185	210	210	210	210	
		C mm	150	240	240	240	300	300	300	450	450	450	450	
		D mm	75	100	100	100	120	120	120	180	180	180	180	
		E mm	135	157	157	157	170	170	170	193	193	193	193	
		F mm	280	200	200	200	210	210	210	235	235	235	235	
Weight [kg]***	PN10/16, ANSI150 (GGG)		10	21	21	21	29	29	29	53	53	53	53	
	PN25/40, ANSI300 (steel)		13	32	32	32	50	50	50	91	91	91	91	
	PN64/100, ANSI600 (steel)		15	33	33	33	50	50	50	97	97	97	97	
Outputs / pulse values *** [imp/m ³]	LF-Type EI (Reed switch)		10	1	1	1	1	1	1	1	1	1	0.1	
	HF-Type A1R (inductive)		28000	10500	10500	10500	6630	6630	6630	6630	2560	2560	2560	
	HF-Type A1S (inductive)		-	21000	21000	21000	13260	13260	13260	-	5120	5120	5120	

* Meter also available with measuring range 1:30

** Δp for natural gas at 1bar abs.

*** Small deviations are possible

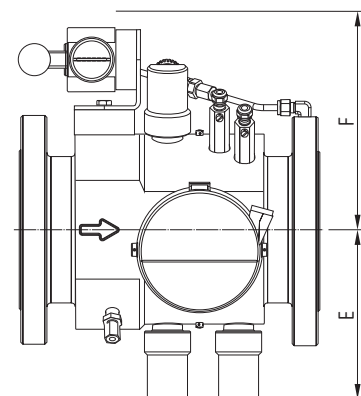
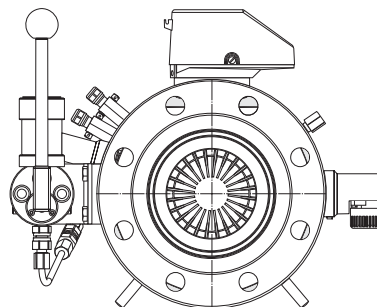
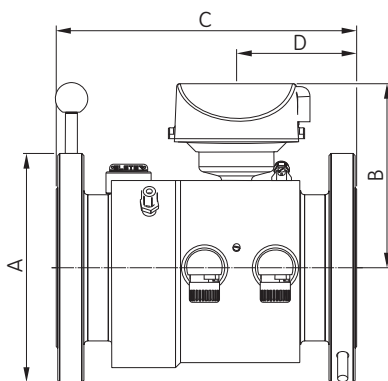

Your contacts



Germany
Elster GmbH
Steinern Str. 19 - 21
55252 Mainz-Kastel
T +49 6134 605 0
F +49 6134 605 223
www.elster-instromet.com
info@elster-instromet.com

Belgium
Elster NV/SA
Rijkmakerlaan 9
2910 Essen
T +32 3 670 0700
F +32 3 667 6940
www.elster-instromet.com
sales@elster-instromet.com

Singapore
Elster-Instromet Sdn. Bhd. (Singapore Branch)
29 Tai Seng Avenue
#06-05A Natural Cool Lifestyle Hub
Singapore 534119
T +65 6247 7728
F +65 6848 9003
sales@elster-instromet.com.sg

TRZ2 EN07
A06.03.2014

73030071

Copyright 2014 Elster GmbH
All rights reserved.
Subject to change without prior notice