



Dival 600
Pressure Regulators

Pressure Regulators

Dival 600

Dival 600 series pressure regulators are direct acting devices for low and medium pressure applications controlled by a diaphragm and counter spring. These regulators are suitable for use with previously filtered, non corrosive gases.

Modular Design

Modular design of the Dival 600 series allows for the addition of a slam shut or an in-line monitor device in the same body without changing the face-to-face dimensions. The truly “top entry design” allows easy periodic maintenance without removing body from the line. The features of Dival 600 series regulators make it a product suitable for any application. The fast response time makes it ideal for burner or industrial applications or whenever sudden changes of flow rate is part of the process. The high accuracy against any inlet pressure variation makes the Dival 600 series an optimum product for gas district systems, an application generally not suitable for direct acting regulators. Extremely easy maintenance and reduced number of parts lower operating expenses and labor.

Accessories on request:

- Silencer
- Incorporated relief valve

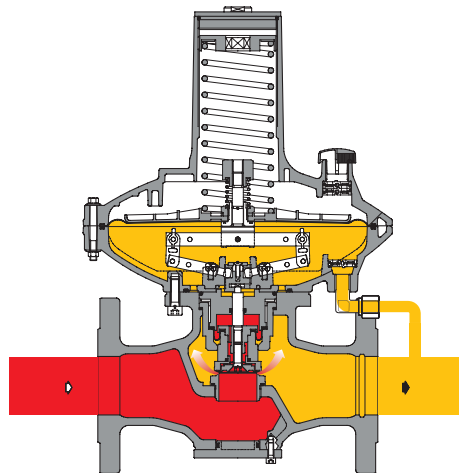

Fig.1

**DESIGNED
WITH YOUR
NEEDS IN MIND**

- COMPACT DESIGN
- EASY MAINTENANCE
- TOP ENTRY
- FAST RESPONSE TIME
- HIGH TURN DOWN RATIO
- HIGH ACCURACY
- LOW OPERATING COST
- WIDE RANGE OF APPLICATIONS

SLAM SHUT
Dival 600

This is a device which stops gas flow immediately whenever downstream pressure exceeds given set-point. Device can also be actuated manually.

LA Slam shut (see figure 2) may be incorporated in the standard regulator and in the in-line monitor. The regulator with the incorporated slam-shut has C_g and K_G coefficients equal to those in table 3. A further advantage of the incorporated slam-shut valve is that it can be retrofitted at any time on a previously installed Dival 600 series without modifying the regulating unit (only with 4 way body). Further, the slam-shut can be positioned in four different positions (rotation on its axis) in such way to be fixed in the most appropriate position versus the surrounding encumbrance if any.

The main features of this slam-shut device are:

- design pressure 232 PSIG for all the components;
- accuracy (AC): 1% of the pressure set-point for pressure increase; 5% for pressure decreasing;
- internal bypass;
- intervention for over pressure and/or under pressure;
- manual push-button control;
- possibility of pneumatic or electromagnetic remote control;
- compact overall dimensions;
- easy maintenance;
- possibility of application of devices for remote signal (contact or inductive microswitches).

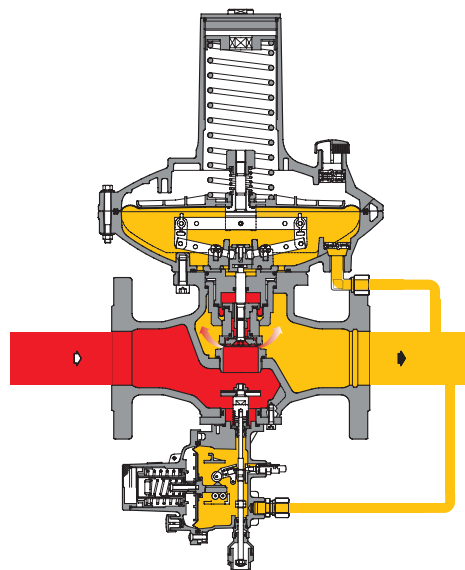
DIVAL 600 + SLAM SHUT LA
Dival 600

Fig. 2

VERSIONS

Dival 600

BODY

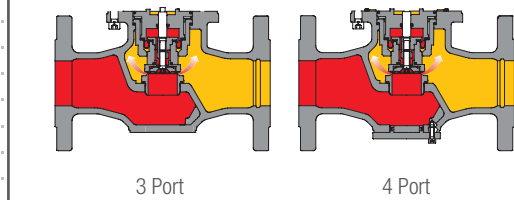

Fig. 3

HEADS

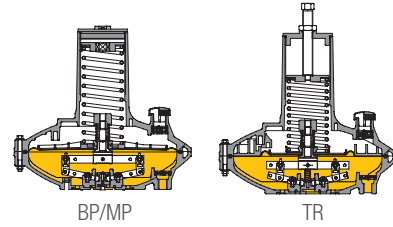

Fig. 4

INCORPORATED SILENCER

Dival 600

Whenever specific noise limits are required, the silencer allows you to considerably reduce the noise emission (dBA) during the gas pressure regulators operation.

The Dival 600 pressure regulator can be supplied with an incorporated silencer in either the standard version, with incorporated slam-shut or in line monitor version.

With the built-in silencer the C_g and K_G valve coefficients are not affected. Pressure reduction and control operate the same manner as in standard version.

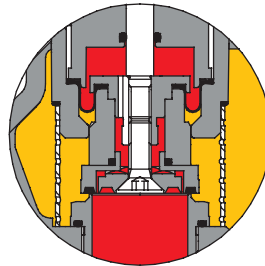
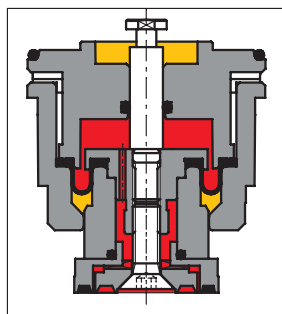

Fig. 5

MONITOR VERSION

Dival 600

Dival 600 series functioning as an in-line monitor is a regulator which, in addition to the standard version, has a mobile assembly balancing device, guaranteeing greater accuracy of regulated pressure, and an equally precise value for the intervention pressure, without risk of interference with the main regulator.



Standard regulator

Fig. 6

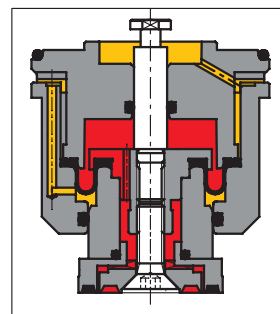

Monitor regulator

Fig. 7

MAIN FEATURES
Dival 600

- Design pressure PS: up to 290 PSIG (20 bar)
- Design temperature: -4° F to + 140° F (-20° C to +60° C)
- Ambient temperature: -4° F to + 140° F (-20° C to +60° C)
- Max inlet pressure Pu: 290 PSIG (20 bar)

- Outlet pressure range of Wd:

Size 1"	from 5"w.c. to 4.9 PSIG (12 to 340) mbar for control head BP/MP from 119 w.c. to 60.9 PSIG (300 to 4200 mbar) for control head TR
Size 1 1/2" - 2"	from 5"w.c. to 34" w.c. (12 to 85 mbar) for control head BP from 32 w.c. to 4.9 PSIG (80 to 340 mbar) for control head MP from 4,3 PSIG to 60.9 PSIG (300 to 4200 mbar) for control head TR

- Accuracy class AC: up to 5
- Lock-up pressure class SG: up to 10
- Available size: 1" (DN 25) - 1 1/2" (DN 40) - 2" (DN 50)
- Flanging: class PN 16/25 according to ISO 7005-1, ISO 7005-2; class ANSI 150RF according to ANSI B16.5, ASME B16.42 and class ANSI 125 FF according to ASME B16.1
- Threaded connections: Size 2" Rp ISO 7-1 or 2"NPTF ASME B1.20.1 (only ductile iron)

MATERIALS
Dival 600

Body	Cast steel ASTM A216 WCB Ductile cast iron GS 400-18 ISO 1083
Head covers	Die cast aluminium EN AC-AISI 12 UNI EN 1706
Diaphragm	Rubberized canvas
Valve seat	Brass
Seals	Nitrile rubber

The characteristics listed above refer to standard products. Special characteristics and materials for specific applications may be supplied upon request.

Coefficient
Dival 600

	ø 280 BP/MP			ø280/TR		
	25	40	50	25	40	50
Nominal diameter (mm)	25	40	50	25	40	50
Size (inches)	1"	1 1/2"	2"	1"	1 1/2"	2"
Cg flow coefficient	269	652	781	315	692	770
K_G flow coefficient	283	685	821	331	727	809
K1 body shape factor	94	94	86	97	95	97

For sizing formula refer to www.fiorentini.com/sizing

CAUTION:

The graph gives a quick reference of maximum recommended regulator capacity, depending on selected size. Values are expressed in actual ft³/h of Natural gas (s.g. 21). To have the data directly in Nm³/h, it is necessary to multiply the value by the outlet pressure value in PSIG – absolute.

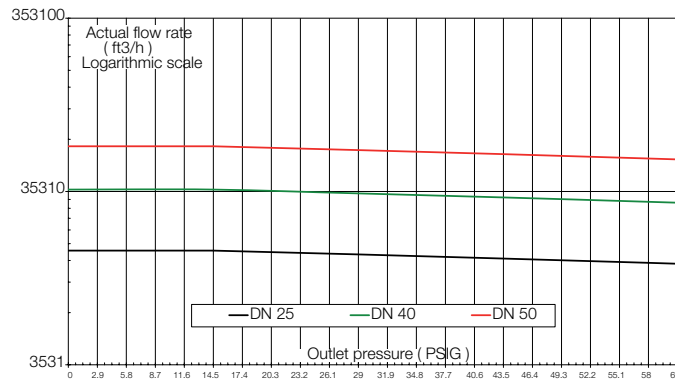

Slam-shut pressure switches

Dival 600

Pressure switch	LA/BP	LA/MP	LA/TR
Set point range for Overpressure (OPSO)	12" w.c. - 72" w.c.	2 - 6.5	3.6 - 80
Set point range for Underpressure (UPSO)	2.4" w.c. - 24" w.c.	0.14 - 3.5	1.45 - 50.8

Working pressure in w.c and PSIG

TYPICAL INSTALLATION

Dival 600

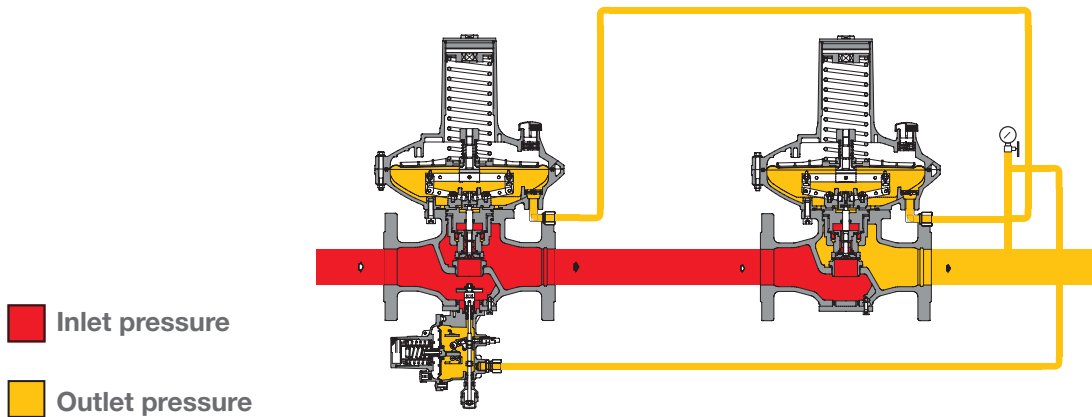

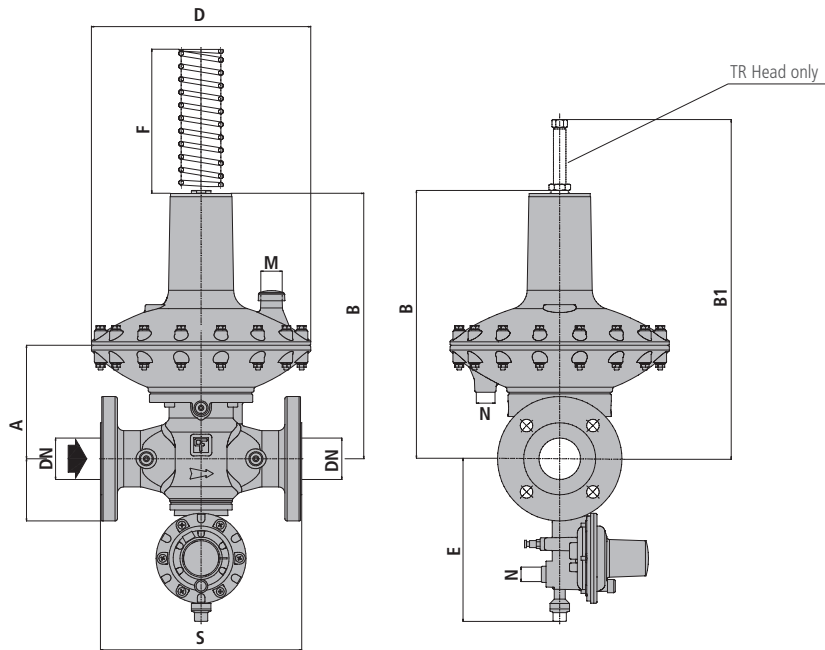
DIMENSIONS
Dival 600

Overall dimensions in Inches
Dival 600

Type	NPS	S	A	B	B1	D	E	F	M	N
Dival 600	1"	7.20	5.71	13.5	17.04	11.02	8.46	7.87	Rp1/2"	Rp1/4"
Dival 600	1 1/2"	8.78	5.71	13.5	17.04	11.02	8.46	7.87	Rp1/2"	Rp1/4"
Dival 600	2"	10	5.71	13.5	17.04	11.02	8.46	7.87	Rp1/2"	Rp1/4"
Dival 600	2" NPT	6	5.71	13.5	17.04	11.02	8.46	7.87	Rp1/2"	Rp1/4"

Weights in pounds
Dival 600

Type	NPS	Dival	Dival with slam shut LA/...
Dival 600	1"	33.06	35.27
Dival 600	1 1/2"	34.48	39.68
Dival 600	2"	44.09	266.76
Dival 600	2" NPT	39.68	41.89

Face to face dimensions S according to ANSI 150 IEC 534-3 and EN 334



Governors



Dival 500



Norval



Fiorentini USA
4555 South Berkeley Lake Road
Norcross, GA 30071

Toll - Free: 888.618.8787
Fax: 770.448.7312

www.fioussa.com

Pietro Fiorentini S.p.A.
via E.Fermi 8/10
I-36057 Arcugnano (VI) Italy

Tel: +39 0444 968.511
Fax: +39 0444 960.468

www.fiorentini.com

This data is not binding. We reserve the right to make changes without prior notice.