



## Mod. DIVAL 500 1" - 500 1"1/2



TEK KADEMELİ  
DÜŞÜK/ORTA/YÜKSEK  
BAŞINÇLI YAY TAHRİKLİ  
DENGELİ OBTÜRATÖRLÜ  
REGÜLATÖRLER

*SINGLE STAGE  
LOW/MEDIUM/HIGH  
PRESSURE SELF-DRIVEN  
REGULATORS WITH  
BALANCED OBTURATOR*

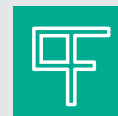
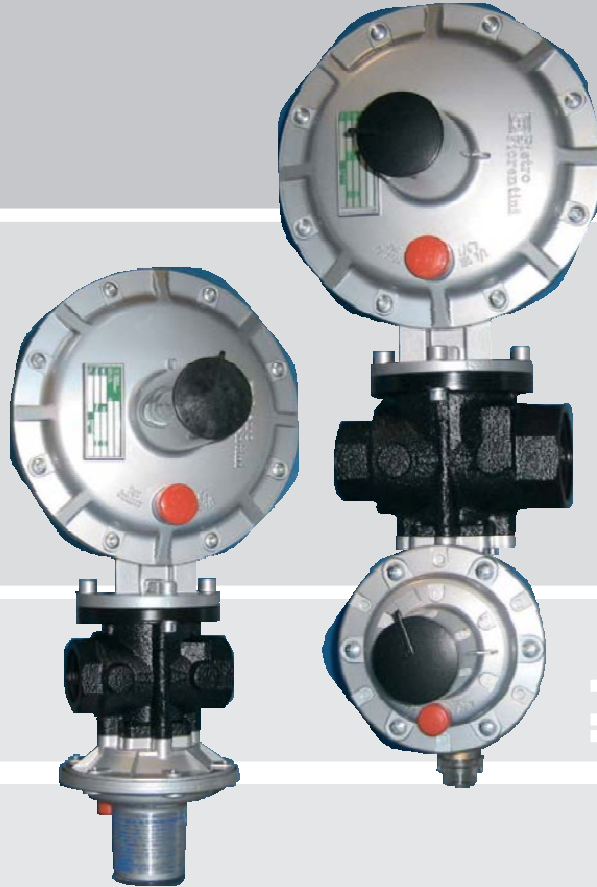

**Pietro  
Fiorentini®**



# Mod. DIVAL 500 1" - 500 1"1/2



1

DIVAL 500 1" LE EMNİYET KAPATMALI  
DIVAL 500 1" WITH LE SLAM-SHUT



2

DIVAL 500 1" EMNİYET KAPATMASIZ  
DIVAL 500 1" WITHOUT SLAM-SHUT



3

DIVAL 500 1"1/2 LA EMNİYET KAPATMALI  
DIVAL 500 1"1/2 WITH LA SLAM-SHUT



4

DIVAL 500 1" EMNİYET KAPATMASIZ, FLANŞLI  
DIVAL 500 1" WITHOUT SLAM-SHUT, WITH FLANGES



5

DIVAL 500 1"1/2 LE EMNİYET KAPATMALI VE FLANŞLI  
DIVAL 500 1"1/2 WITH LE SLAM-SHUT AND FLANGES



6

DIVAL 500 1"1/2 LE EMNİYET KAPATMALI  
DIVAL 500 1"1/2 WITH LE SLAM-SHUT

**■** GİRİŞ BASINCI  
INLET PRESSURE

**■** ÇIKIŞ BASINCI  
OUTLET PRESSURE



## EBATLAR - OVERALL DIMENSIONS - DIVAL 500+LE

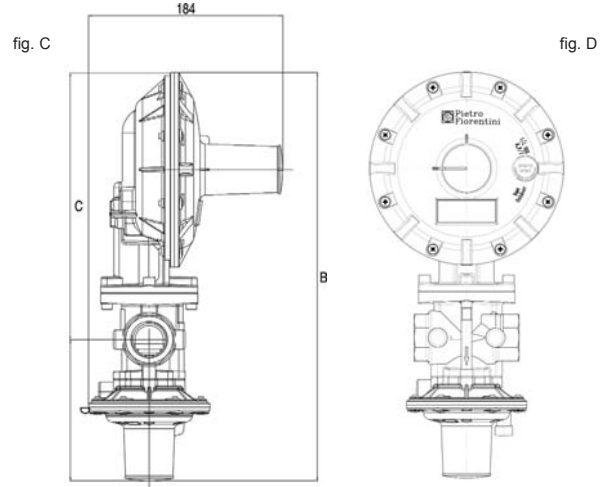

DIVAL 500 1"		DIVAL 500 1 1/2"	
A	100±1	A	130±1
B	390±2	B	398±2
C	255±1	C	257±1
D	135±1	D	141 ±1
DnE	1" ISO 7/1	DnE	1" ISO 7/1
DnU	1" ISO 7/1	DnU	1 1/2 ISO 7/1

tab. 1

## EBATLAR - OVERALL DIMENSIONS - DIVAL 500+LA

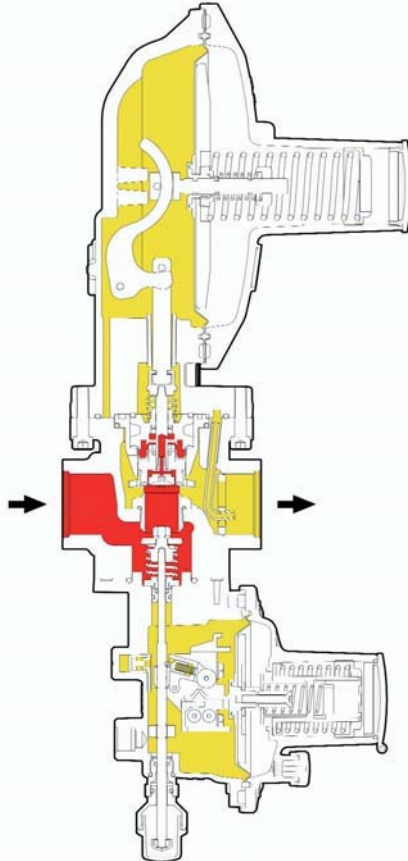

**MALZEMELER / MATERIALS**  
GÖVDE / BODY  
EN-GJS400-15 UNI EN 1563  
KAPLAMA / COVERS  
ALLUMINIUM EN AB 44100  
**DIŞ YÜZEY UYGULAMALARI / EXTERNAL TREATMENTS**  
GÖVDE / BODY + KAPLAMA / COVERS  
KUMLAMA +FOSFATLAMA+TOZ POLÜRETAN KAPLAMA  
SANDBLASTING+PHOSPHATING+ DUST POLYURETHANE COATING

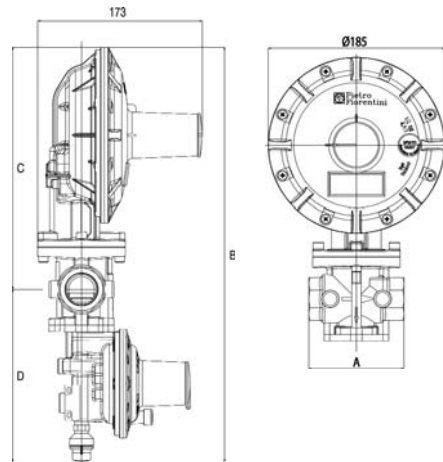

DIVAL 500 1"		DIVAL 500 1 1/2"	
A	100±1	A	130±1
B	437±2	B	445±2
C	255±1	C	257±1
D	182±1	D	188 ±1
DnE	1" ISO 7/1	DnE	1" ISO 7/1
DnU	1" ISO 7/1	DnU	1 1/2 ISO 7/1

tab. 2

# 500 1" - 500 1"1/2



## YAY AYAR (ANA Kafa) ARALIKLARI ADJUSTMENT SPRINGS RANGE

RELIEF VANA BASINÇLARI (Pd e göre)  
DIFFERENTIAL RELIEF VALVE OPERATING  
PRESSURE WITH REFERENCE TO THE NOMINAL  
OUTLET PRESSURE (Pd)

Wd	
DIVAL BP	
COD.	ARALIK (mbar) RANGE (mbar)
644.70137	13÷18
644.70068	18÷25
644.70139	25÷35
644.70140	35÷65
644.70071	65÷100

Wd	
DIVAL MP	
COD.	ARALIK (mbar) RANGE (mbar)
644.70071	100÷170
644.70329	170÷300
DIVAL TR	
644.70143	300÷600
644.70144	600÷1000
644.70145	1000÷1800
644.70151	1800÷2500

TİP VERSION	COD.	ARALIK (mbar) RANGE (mbar)
BP	644.70024	10÷18
	644.70031	18÷50
MP	644.70038	30÷100
MP	644.70038	50÷95
	644.70045	260÷700
	644.70046	700÷1000

## SLAM-SHUT LA

### YAY AYAR ARALIKLARI(MAX SSV) ADJUSTMENT SPRINGS RANGE

Wdo			
COD.	ARALIK (mbar) / RANGE (mbar)		
	BP	MP	TR
644.70112	30÷50		
644.70115	50÷180		
644.70115		140÷180	
644.70116		180÷280	
644.70051		280÷450	
644.70116			250÷550
644.70151			550÷850
644.70057			850÷1400
644.70058			1400÷2500
644.70059			2500÷4000
644.70060			4000÷5500

### YAY AYAR ARALIKLARI(MİN SSV) ADJUSTMENT SPRINGS RANGE

Wdu			
COD.	ARALIK (mbar) / RANGE (mbar)		
	BP	MP	TR
644.70024	6÷60		
644.70024		10÷60	
644.70038		60÷240	
644.70038			100÷500
644.70045			500÷1000
644.70046			1000÷2000
644.70149			2000÷3500

## SLAM-SHUT LE

### YAY AYAR ARALIKLARI(MAX SSV) ADJUSTMENT SPRINGS RANGE

Wdo			
COD.	ARALIK (mbar) / RANGE (mbar)		
	BP	MP	TR
644.70111	32÷55		
644.70113	55÷100		
644.70114	100÷160		
644.70115		155÷210	
644.70116		210÷330	
644.70051		330÷500	
644.70051			450÷850
644.70157			850÷1450
644.70058			1450÷2300
644.70059			2300÷3000

### YAY AYAR ARALIKLARI(MİN SSV) ADJUSTMENT SPRINGS RANGE

Wdu			
COD.	ARALIK (mbar) / RANGE (mbar)		
	BP	MP	TR
644.70308	6÷15		
644.70128	15÷40		
644.70024	40÷80		
644.70031		80÷140	
644.70038		140÷250	
644.70031			100÷300
644.70038			300÷700
644.70045			700÷1500

## GİRİŞ

Yay tahrikli, dengelenmiş obtüratörlü Dival 500 serisi regülatörler, düşük, orta ve yüksek basınç için tasarlanmıştır.

Emniyet kapatmalı Dival serisi regülatörlerde, içten hissedici mevcuttur. Ancak daha yüksek kapasite ve daha iyi hassasiyet için talebe göre, regülatör ve emniyet kapatma için, dışarıdan hissedici hat bağlanması da mümkündür.

Sanayi ve ticari uygulamalarda sıklıkla tercih edilen Dival, Doğal gaz, LPG ve korozif olmayan tüm gazlar için uygundur.

Dengelenmiş obtüratörlü özel regülatör dizaynı ile Dival' in avantajları;

- yüksek akış debisi katsayısı
- yüksek hassasiyet, en üst düzey debilerde bile
- düşürülmüş kapatma yüzeyi
- kısaltılmış cevap süresi
- sıfır akışta, sıfır iç sızıntı
- normalde kapalı tip (fail to open)
- gövdeyi hattan sökmeden periyodik bakım imkanı
- mevcut hat üzerinde, değişiklik yapmadan, emniyet kapatma OPSO/UPSO (maksimum basınç/ minimum basınç kapama) ayarlarına (LA tipleri için).

## TEMEL ÖZELLİKLER

- Giriş basıncı aralığı bpu: BP:  
0.5+10 bar  
MP / TR: 0.5+20 bar
- Maksimum müsaade edilen basınç PS: BP:  
10 bar  
MP / TR: 20 bar
- Çıkış basıncı aralığı Wd: BP:  
15+100 mbar  
MP: 100+300 mbar  
TR: 300+2500mbar
- Hassasiyet sınıfı: AC 10-15%
- Kapama basıncı sınıfı: SG Max 25%
- Sıcaklık sınıfı: 2 (-20°C +60°C)
- Emniyet kapama ayar aralıkları LA:PS 20bar  
Wd OPSO BP 30+180 mbar  
MP140+450 mbar  
TR 250+5500 mbar  
Wd UPSO BP 6+60 mbar  
MP 10+240 mbar  
TR 100+3500 mbar
- Emniyet kapama ayar aralıkları LE:PS 10bar  
Wd OPSO BP 32+160 mbar  
MP155+500 mbar  
TR 450+3000 mbar  
Wd UPSO BP 6+80 mbar  
MP 80+250 mbar  
TR 100+1500 mbar

## GÜVENLİK SİSTEMLERİ VE AKSESUARLAR

- Aşırı basınçta kapatma
- Alçak basınçta kapatma
- Düşük beslemede emniyet kapatma
- Yangın vanası (sadece LA).
- Tahliye vanası.
- Entegre By-pass.
- Emniyet kapamanın elle resetlenmesi (varsa)

97/23 CE PED DİREKTİFLERİNE UYGUN

## INTRODUCTION

The DIVAL 500 series of spring loaded, diaphragm controlled balanced plug regulators are suitable for low, medium and high pressure.

Divals and shut-off device series regulators are supplied with internal sensing lines. Both the regulator and the shut-off device are preset for optional connection to an external sensing line by the customer.

They are widely used in both civil and industrial installations using Natural Gas, LPG and other non corrosive gases.

The special regulator design combined with a balanced plug result in:

- high flow rate coefficient,
- high accuracy, even at maximum flow rates,
- reduced lock up pressure zone and lock up pressure,
- reduced response times,
- no internal leakage at zero flow rate,
- fail to open type,
- periodical maintenance without disassembling the body from the pipework,
- ability to retrofit the slam-shut OPSO/UPSO, (only LA model) without modifying the existing piping.

## MAIN FEATURES

- Inlet pressure range bpu:  
BP: 0.5+10 bar - bpu: 7.2+145 Psi  
MP / TR: 0.5+20 bar - bpu: 7.2+290 Psi
- Max allowable pressure PS:  
BP: 10 bar - PS 145 Psi  
MP / TR: 20 bar - PS 290 Psi
- Outlet pressure range Wd:  
BP: 15+100 mbar - BP: 0.21+40.1" wc  
MP: 100+300 mbar - MP: 40.1+120.5" wc  
TR: 300+2500 mbar - TR: 120.5+1004.6" wc
- Accuracy class: AC 10-15%
- Lock up pressure class: SG 25% Max
- Temperature class: 2 (-20°C +60°C) - (-68°F +140°F)
- Shut - off device setting range model LA PS 20bar - 290 PSI:  
Wd OPSO BP 30+180 mbar - Wd OPSO: 12+72.3" wc  
Wd OPSO MP 40+450 mbar - Wd OPSO: 56.2+180.8" wc  
Wd OPSO TR 250+5500 mbar - Wd OPSO: 100.4+2210" wc  
Wd UPSO BP 6+60 mbar - Wd UPSO: 2.4+24.1" wc  
Wd UPSO MP 10+240 mbar - Wd UPSO: 4.0+96.4" wc  
Wd UPSO TR 100+3500 mbar - Wd UPSO: 40.1+1406.5" wc
- Shut - off device setting range model LE PS 10bar - 145 PSI:  
Wd OPSO BP 32+160 mbar - Wd OPSO: 12.8+64.3" wc  
Wd OPSO MP 155+500 mbar - Wd OPSO: 62.3+200.9" wc  
Wd OPSO TR 450+3000 mbar - Wd OPSO: 180.8+1205.6" wc  
Wd UPSO BP 6+80 mbar - Wd UPSO: 2.41+32.1" wc  
Wd UPSO MP 80+250 mbar - Wd UPSO: 32.1+100.4" wc  
Wd UPSO TR 100+1500 mbar - Wd UPSO: 40.2+602.8" wc

## SAFETY DEVICES AND ACCESSORIES

- Over pressure shut-off device (OPSO).
- Under pressure shut-off device (UPSO).
- Safety shut-off device for lack of feeding.
- Thermic valve (only LA).
- Relief valve.
- Integrated by-pass.
- The reset of the safety shut-off devices (whenever present) is solely manual.

CONFORMING TO THE 97/23 CE PED DIRECTIVE

# 500 1" - 500 1"1/2

## DIVAL 500 1" DAHİLİ HİSSEDİCİ AKTİF\*

DIVAL 500 1" WITH INTERNAL WITH PRESETTING EXTERNAL SENSING LINE

Pd:15-100mbar BP Portata stmc/h G.N.				Pd:100-300mbar MP Portata stmc/h G.N.				Pd:300-1000mbar TR Portata stmc/h G.N.				Pd:1000-3000mbar TR Portata stmc/h G.N.			
Pu bar	AC5	AC10	AC20	Pu bar	AC5	AC10	AC20	Pu bar	AC5	AC10	AC20	Pu bar	AC5	AC10	AC20
Pd +0,5bar	75	95	105	Pd +0,5bar	110	130	140	Pd +0,5bar	50	80	100	Pd +0,5bar	100	160	200
Pd +1bar	75	125	140	Pd +1bar	150	180	200	Pd +1bar	75	130	150	Pd +1bar	150	270	300
Pd +2,5bar	100	125	140	Pd +2,5bar	250	300	300	Pd +2,5bar	120	200	250	Pd +2,5bar	300	480	500
Pd +5,0bar	90	140	160	Pd +5,0bar	300	300	300	Pd +5,0bar	130	350	350	Pd +5,0bar	350	350	350

## DIVAL 500 1" DAHİLİ VE HARİCİ HİSSEDİCİ HAT AKTİF\*

DIVAL 500 1" WITH INTERNAL AND EXTERNAL SENSING LINE ACTIVE\*

Pd:15-100mbar BP Portata stmc/h G.N.				Pd:100-300mbar MP Portata stmc/h G.N.				Pd:300-1000mbar TR Portata stmc/h G.N.				Pd:1000-3000mbar TR Portata stmc/h G.N.			
Pu bar	AC5	AC10	AC20	Pu bar	AC5	AC10	AC20	Pu bar	AC5	AC10	AC20	Pu bar	AC5	AC10	AC20
Pd +0,5bar	50	75	100	Pd +0,5bar	100	140	150	Pd +0,5bar	50	80	100	Pd +0,5bar	100	160	200
Pd +1bar	75	140	150	Pd +1bar	140	200	230	Pd +1bar	75	130	150	Pd +1bar	150	270	300
Pd +2,5bar	120	200	240	Pd +2,5bar	200	300	300	Pd +2,5bar	120	200	250	Pd +2,5bar	300	480	500
Pd +5,0bar	140	250	300	Pd +5,0bar	350	350	350	Pd +5,0bar	130	350	350	Pd +5,0bar	350	350	350

\* Müşterinin yaptığı harici bağlantı / Connection to the external sense line by the client

## DIVAL 500 1" 1/2 DAHİLİ HİSSEDİCİ AKTİF\*

DIVAL 500 1" 1/2 WITH INTERNAL WITH PRESETTING EXTERNAL SENSING LINE

Pd:15-100mbar BP Portata stmc/h G.N.				Pd:100-300mbar MP Portata stmc/h G.N.				Pd:300-1000mbar TR Portata stmc/h G.N.				Pd:1000-3000mbar TR Portata stmc/h G.N.			
Pu bar	AC5	AC10	AC20	Pu bar	AC5	AC10	AC20	Pu bar	AC5	AC10	AC20	Pu bar	AC5	AC10	AC20
Pd +0,5bar	75	100	110	Pd +0,5bar	120	150	170	Pd +0,5bar	60	90	110	Pd +0,5bar	110	160	200
Pd +1bar	160	180	200	Pd +1bar	170	250	280	Pd +1bar	75	140	160	Pd +1bar	180	350	400
Pd +2,5bar	140	200	200	Pd +2,5bar	350	380	400	Pd +2,5bar	160	250	280	Pd +2,5bar	320	500	500
Pd +5,0bar	130	160	180	Pd +5,0bar	350	400	450	Pd +5,0bar	350	450	500	Pd +5,0bar	350	500	500

## DIVAL 500 1" 1/2 DAHİLİ VE HARİCİ HİSSEDİCİ HAT AKTİF\*

DIVAL 500 1" 1/2 WITH INTERNAL AND EXTERNAL SENSING LINE ACTIVE\*

Pd:15-100mbar BP Portata stmc/h G.N.				Pd:100-300mbar MP Portata stmc/h G.N.				Pd:300-1000mbar TR Portata stmc/h G.N.				Pd:1000-3000mbar TR Portata stmc/h G.N.			
Pu bar	AC5	AC10	AC20	Pu bar	AC5	AC10	AC20	Pu bar	AC5	AC10	AC20	Pu bar	AC5	AC10	AC20
Pd +0,5bar	70	110	115	Pd +0,5bar	100	160	180	Pd +0,5bar	60	90	110	Pd +0,5bar	110	160	200
Pd +1bar	160	170	180	Pd +1bar	160	240	280	Pd +1bar	75	140	160	Pd +1bar	180	350	400
Pd +2,5bar	300	350	350	Pd +2,5bar	500	500	500	Pd +2,5bar	160	250	280	Pd +2,5bar	320	500	500
Pd +5,0bar	200	250	300	Pd +5,0bar	500	500	500	Pd +5,0bar	350	450	500	Pd +5,0bar	350	500	500

\* Müşterinin yaptığı harici bağlantı / Connection to the external sense line by the client

LPG akış debisi: tablodaki değerler x 1.2

Azot akış debisi: moltiplicare il valore in tabella x 0.789

AÇIKLAMALAR:

Pd: Çıkış basıncı - Pu: Giriş basıncı - Ac: Hassasiyet

LPG flow rate: multiply the value in the table x 1.2

Azote flow rate: multiply the value in the table x 0.789

LEGEND:

Pd: Outlet pressure - Pu: Inlet pressure - Ac: Accuracy

## GİRİŞ - INLET

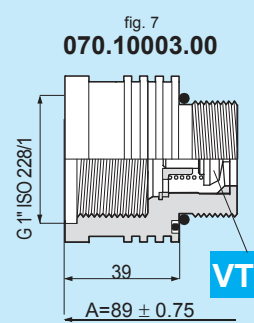
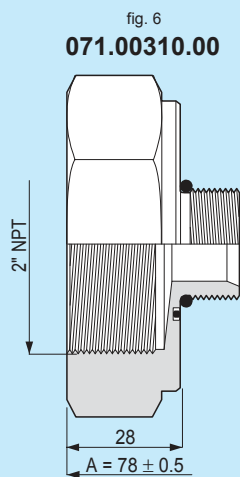
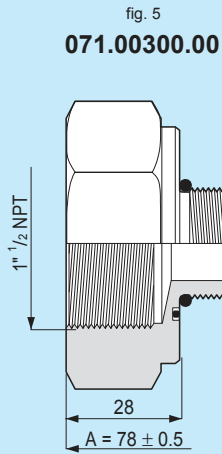
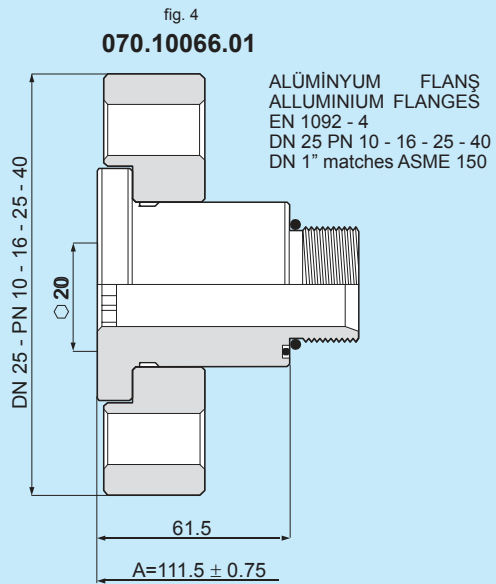
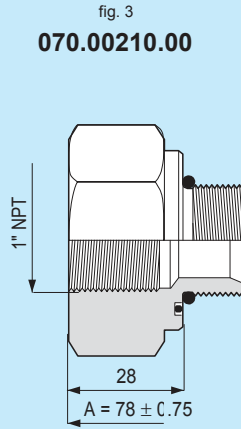
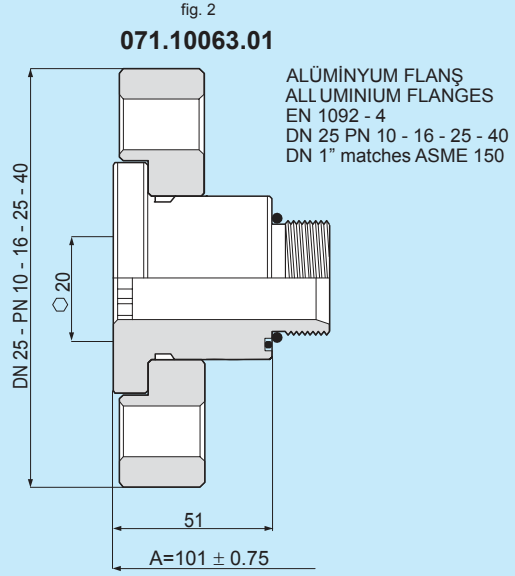
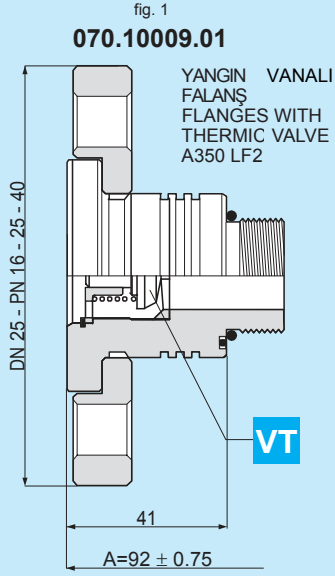

**VT** = yangin vanalı  
 with Thermic Valve



ÇIKIŞ - OUTLET

fig. 1

**071.10063.01**

ALÜMİNYUM FLANS  
ALLUMINIUM FLANGES  
EN 1092 - 4  
DN 25 PN 10 - 16 - 25 - 40  
DN 1" matches ASME 150

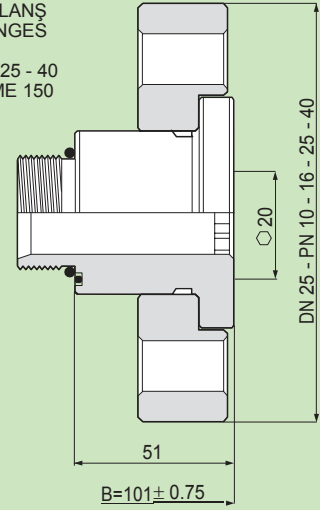

fig. 2

**070.00210.00**

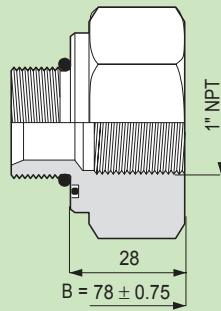

fig. 3

**071.00300.00**

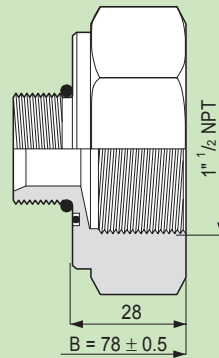

fig. 4

**071.00310.00**

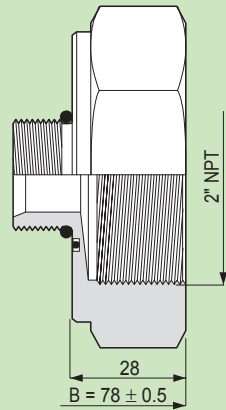
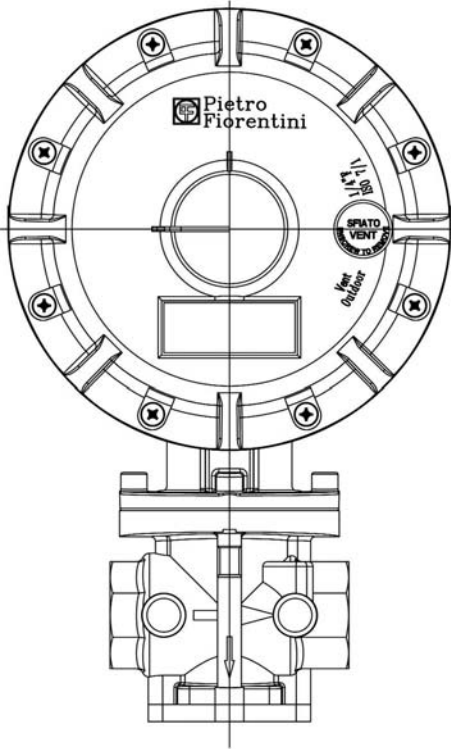
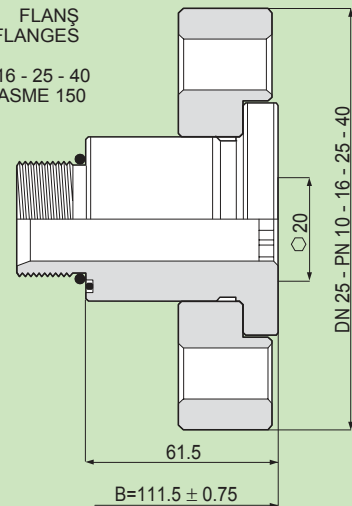

fig. 5

**070.10066.01**

ALÜMİNYUM FLANS  
ALLUMINIUM FLANGES  
EN 1092 - 4  
DN 25 PN 10 - 16 - 25 - 40  
DN 1" matches ASME 150



## GİRİŞ - INLET

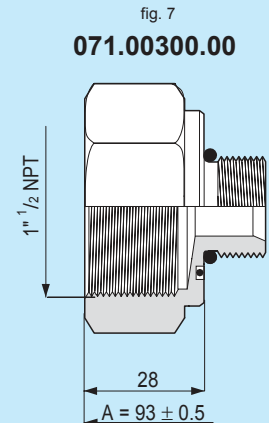
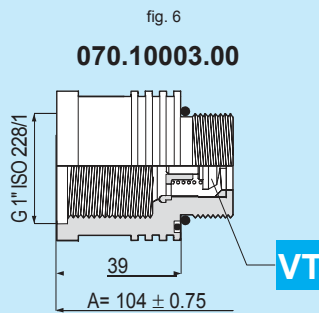
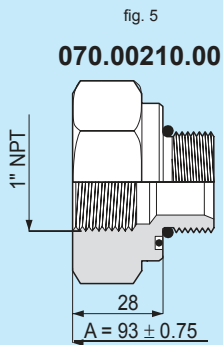
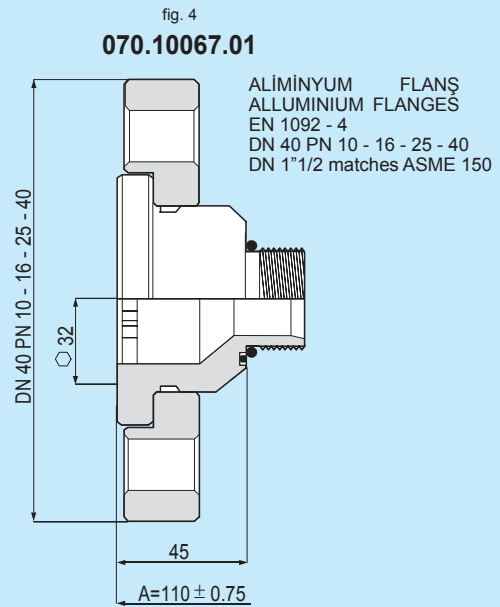
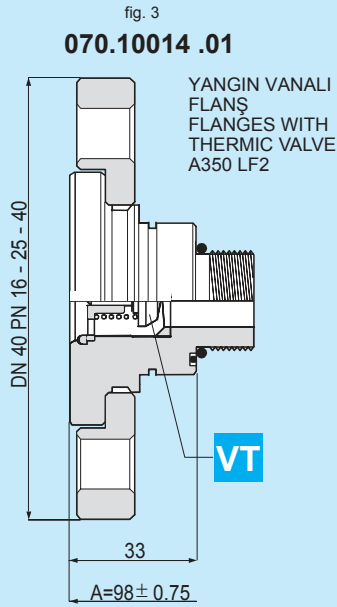
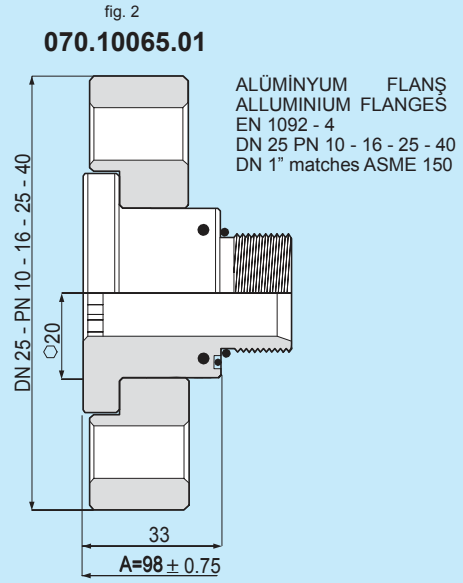
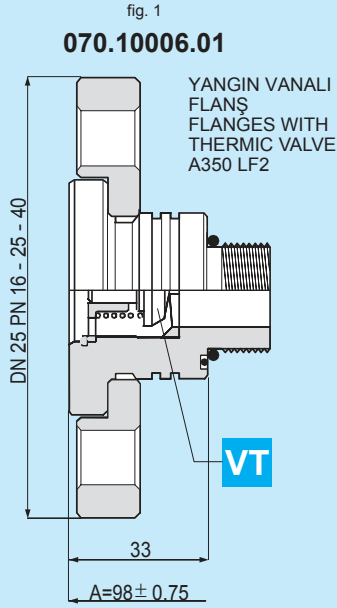

**VT** = Yangin vanalı / with Thermic Valve

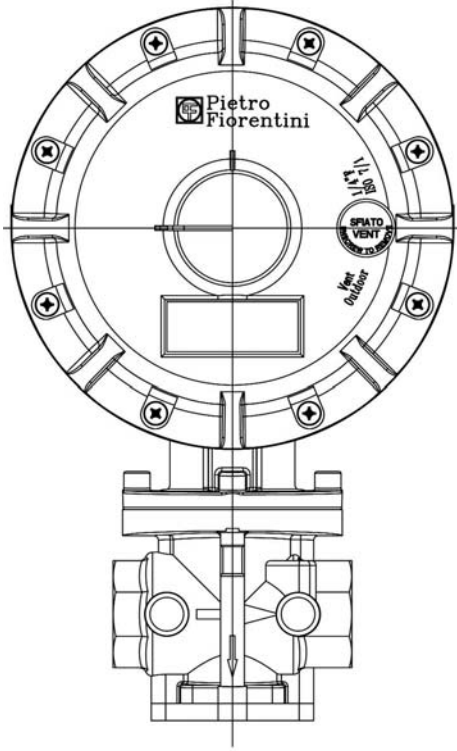
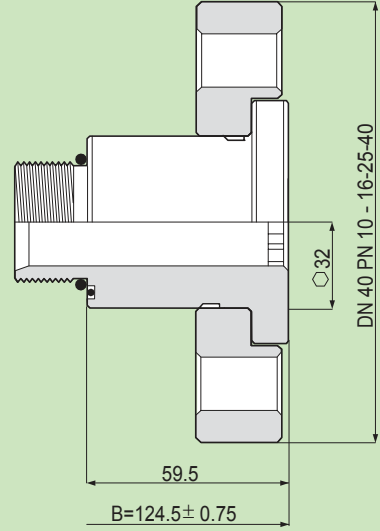

fig. H

**ÇIKIŞ - OUTLET**

fig. 1

**071.10062.01**



ALİMİNYUM FLANŞ  
ALLUMINIUM FLANGES  
EN 1092 - 4  
DN 40 PN 10 - 16 - 25 - 40  
DN 1 1/2 matches ASME 150

fig. 2

**071.00320.00**

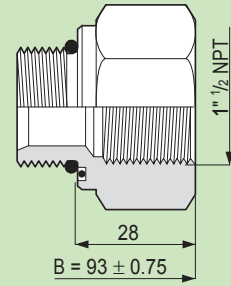
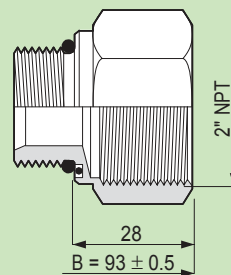

fig. 3

**071.00390.00**



ETIKET KODLAMASI  
T-00211 Mod. DIVAL 500

LEGENDA	
① ②	Sigla prodotto
③	Modello Regolatore
④	Accessori
⑤	Targhettatura
⑥	Connessioni entrata/uscita
⑦	Pressione d'ingresso MIN
⑧	Pressione d'ingresso MAX
⑨ ⑩	Tarature
⑪	Versione
STD	Standard
G.N.	Gas Naturale
G.P.L.	Gas Petrolio Liquefatto
BP	Bassa Pressione
MP	Media Pressione
TR	Testata Ridotta (Alta Pressione)
AP	Alta Pressione

MODELLO	
G.N. / G.P.L.	
A	DIVAL 500 1" BP
B	DIVAL 500 1" MP
C	DIVAL 500 1" TR
G	DIVAL 500 1"1/2 BP
H	DIVAL 500 1"1/2 MP
I	DIVAL 500 1"1/2 TR

targhettatura			
LINGUA	LOGO	U.M.	
A	ITALIANO / INGLESE	PERSONALIZZATO CLIENTE	MBAR
B	.		MBAR
C	ITALIANO / INGLESE	PIETRO FIORENTINI	MBAR
D	.		
E	.		
F	ITALIANO / INGLESE	PIETRO FIORENTINI	KPA
G	ITALIANO / INGLESE	PIETRO FIORENTINI	mmH2o
H	INGLESE	PIETRO FIORENTINI	IMPERIALI
K	.		

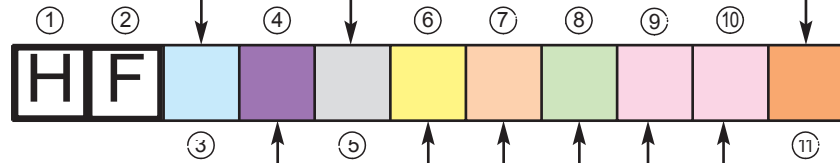

	BLOCCO LE	BLOCCO LA	SFIORO
A	---	SI	SI
B	---	SI	NO
C	---	SI	BLOCCATO
D	NO	NO	SI
E	NO	NO	NO
F	NO	NO	BLOCCATO
G	SI	---	SI
H	SI	---	NO
I	SI	---	BLOCCATO

Con distanziale (riattivabile)

Con 3 OR (non riattivabile)

	CONNESSIONI	DIVAL 500 1"		DIVAL 500 1" 1/2	
		DnE (1")	DnU (1")	DnE (1")	DnU (1"1/2)
0	Corpo Rp ISO 7/1	Corpo	Corpo	Corpo	Corpo
1	.				
2	.				
3	DnE/U 25 PN40 -ASME-(202)	071.10063.01	071.10063.01	-----	-----
4	DnE/U 25 PN40 -ASME-(223)	070.10066.01	070.10066.01	-----	-----
5	DnE 25 x DnU 40 PN40 (ASME)	-----	-----	070.10065.01	071.10062.01
6	DnE/U 40 PN40 (ASME)	-----	-----	070.10067.01	071.10062.01
7	.				
8	.				
9	Raccordi NPT	070.00210.00	070.00210.00	070.00210.00	071.00320.00
A	1" NPT x 2" NPT	070.00210.00	071.00310.00	070.00210.00	071.00390.00
B	1"1/2NPT x 1"1/2NPT	071.00300.00	071.00300.00	071.00300.00	071.00320.00
C	DNE/U 1" ANSI 300	070.10034.01	070.10034.01		
D	3/4" NPT x 1" NPT	071.00640.00	070.00210.00		

Açıklama amaçlıdır.

Tüm mümkün modelleri oluşturmak için lütfen

aşağıdaki web sitesini deneyin:

[www.fiorenzo.com/Servizi Fiorentini](http://www.fiorenzo.com/Servizi Fiorentini)

orada yukarıda yazan açıklamaların İngilizcesini

de bulabilirsiniz.

This table is only demonstration.

To create all allowable versions please

refer to FM configurator on website:

[www.fiorenzo.com/Servizi Fiorentini](http://www.fiorenzo.com/Servizi Fiorentini)

where you can also find english translation



## PAKET EBATLARI - PACKAGING DIMENSIONS

ÜRÜN REFERENCE	ADET PIECES Nr.	EBATLAR DIMENSIONS cm	HACİM VOLUME m <sup>3</sup>	AĞIRLIK WEIGHT Kg	PALLET MAX LxPxH cm		
					ADET PIECES Nr.	AĞIRLIK WEIGHT Kg	HACİM VOLUME m <sup>3</sup>
DIVAL 500 1" - 500 1"1/2	1	20x20x25	0.010	3.0+3.6	120x80x150		
					120	360-432	1.44
DIVAL 500 1" - 500 1"1/2 + SLUM-SHUT	1	46x20x22.5	0.020	3.4+4.3	120x80x150		
					42	143-181	1.44

Bu dökümanın amacı imalatçıya ya da montajcıya faydalı bilgiler sağlamak..

Ürün değerlendirmesi ve yenilemesi kapsamında FIORENTINI MINIREG S.p.A istediği zaman değişiklik yapma hakkına sahiptir.

Bu katalogtaki bilgi ve fotoğraflar sadece geneli kapsamaktadır. Teknik servisimiz, türlü farklı ihtiyaca cevap verebilecek niteliktedir.

FIORENTINI MINIREG S.p.A. bilgilendirme yapmadan değişiklik yapma hakkını saklı tutar.

The aim of this document is to provide useful information to the designer and/or installer.

Upon consideration of the normal product evolution, FIORENTINI MINIREG S.p.A. is at any time free to modify data concerning the items presented.

It is necessary to state that the photographs and the news concerning this catalogue are to be considered as general information only.

Our TECHNICAL ASSISTANCE is available for further information concerning the exact definition of the product characteristics.

Fiorentini Minireg reserves the right to change this information without previous notice with the view of continuous improvement.

### AÇIKLAMALAR

- Ps** = Müsade edilen maksimum basınç  
**Pu** = Giriş basıncı  
**Pu max** = Maksimum giriş basıncı  
**Pd** = Çıkış basıncı  
**Pd max** = Maksimum çıkış basıncı  
**Wd** = Ayar aralığı  
**Wdo** = Maks. kapatma ayar aralığı  
**Wdu** = Min. ayar aralığı  
**Bpu** = Giriş basıncı aralığı  
**Pds** = Ayar değeri  
**AC/AG** = Hassasiyet sınıfı  
**SG** = Kapama sınıfı  
**Q** = Hacimsel debi  
**C<sub>1</sub>** = Gövde şekli faktörü  
**Cg** = Debi katsayısı

### LEGEND:

- Ps** = Max allowable pressure  
**Pu** = Inlet pressure  
**Pu max** = Max inlet pressure  
**Pd** = Outlet pressure  
**Pd max** = Permissible outlet pressure  
**Wd** = Set range  
**Wdo** = Opso set range  
**Wdu** = Upso set range  
**Bpu** = Inlet pressure range  
**Pds** = Set point  
**AC/AG** = Accuracy class  
**SG** = Lock up pressure class  
**Q** = Volumetric flowrate  
**C<sub>1</sub>** = Body shape factor  
**Cg** = Flow rate coefficient

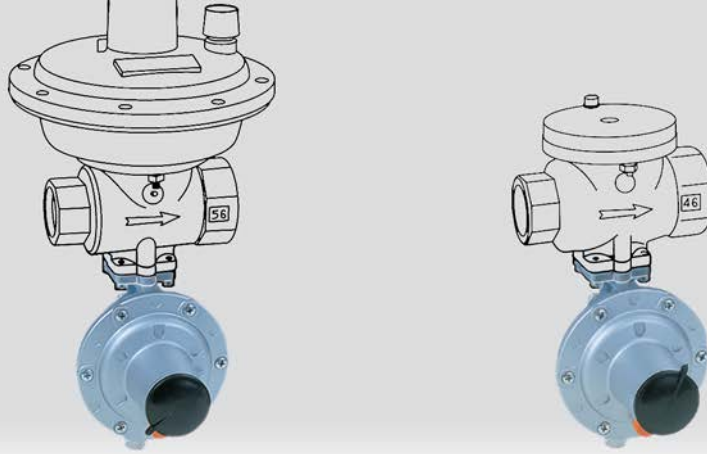

## GİRİŞ

LA kapatma vanası veya basınç switch vanası, tüm DIVAL ve DILOCK regülatörlere uygulanabilen emniyet aygıtıdır.

Kapama vanalarının amacı, herhangi bir tehlikeli durum oluşunca, gaz akışını kesmektir.

Bu işlem, regülatörün ya da kapama aygıtının çıkışındaki bir noktadan ölçüm alınarak yapılır.

Doğal gaz, LPG ve tüm korozif olmayan gazlarda kullanıma uygundur.

## INTRODUCTION

The mod. LA shut-off valve or pressure switch valve is a safety device which may be applied to the regulation equipment to all DIVAL series regulators and to DILOCK shut-off valves.

The purpose of the shut-off valves is to interrupt the gas flow, through an external plug, each time a dangerous situation occurs.

Their operation is sensed at a point downstream of the regulator or shut-off device.

They are suitable for Natural gas, LPG and other non corrosive gases.

## TEMEL ÖZELLİKLER

- Sıcaklık sınıfı: 2 (-20°C + 60°C).
- Maksimum basınç: PS 20 bar.
- Yüksek giriş basınçlarında bile kolay resetlenme.
- Yalnızca elle resetlenebilir (sıcaklık artışı durumu hariç).
- Güvenlik klapesi kafada, böylelikle herhangi bir hasarda mühürü kontrol edebilme imkanı..
- Test düğmesi tüm DIVAL lerde standarttır.
- Operasyon durumunda kullanılmak üzere elektrik sinyal kontağı eklenebilir (opsiyonel).

Aygıt şu durumlarda müdahale eder:

- YÜKSEK BASINÇ – görüntülenen basıncın kalibre edilmiş değerinin üstüne çıkması durumunda. (kullanımdaki yayın sınırlarına göre kalibrasyon değişebilir).
- ALÇAK BASINÇ - görüntülenen basıncın kalibre edilmiş değerinin altına inmesi durumunda. (kullanımdaki yayın sınırlarına göre kalibrasyon değişebilir).
- SICAKLIK ARTIŞI – vana sıcaklığı 170/190°C üzerine çıkması durumunda

## MAIN FEATURES

- Temperature class: 2 (-20°C + 60°C); (-68°F +140°F).
- Maximum pressure: Ps 20 bar - Ps 290 Psi.
- Easy resetting with high inlet pressures.
- Manual reset only (except for the intervention in case of Temperature increase).
- Security tab is included on the cap to enable checking the seal for any violation.
- Inlet pressure to the valve is measured upstream.
- "Test" button is standard for DIVAL models 160 and 250, 520 and 522.
- An electric contact signal can be fitted to confirm the state of operation (upon request).

The device operates in the following cases:

- OVER PRESSURE - in case the monitoring pressure exceeds the calibration limits. (the calibration changes from the outside according to the range forecast by the spring in use).
- UNDER PRESSURE - in case the monitoring pressure goes below the calibration limits (the calibration changes from the outside according to the range forecast by the spring in use).
- TEMPERATURE INCREASE - in case the valve temperature goes further 170/190°C - 338/374°F.

97/23 CE PED DİREKTİFLERİNE UYGUN

CONFORMING TO THE 97/23 CE PED DIRECTIVE

ETİKET KODLAMASI  
T-00210 Mod. LA

LEGENDA	
① ②	Sigla prodotto
③	Modello
④	Tipo di intervento
⑤	Targhettatura
⑥ ⑦	Tarature
⑧ ⑨	Versione
STD	Standard
G.N.	Gas Naturale
G.P.L.	Gas Petrolio Liquefatto
BP	Bassa Pressione
MP	Media Pressione
TR	Testata Ridotta (Alta Pressione)

MODELLO	
G.N. / G.P.L.	
A	x DIVAL 507 - 500 1"
B	x DIVAL 512 - 500 1" 1/2
C	.
D	.
E	.
F	x DIVAL P.F.
G	.
H	x DIVAL 520 - 522

TIPO	BLOCCO	
	MAX	MIN
A	BP	SI NO (riattivabile)
B	BP	SI SI
C	MP	SI NO (riattivabile)
D	MP	SI SI
E	TR	SI NO (riattivabile)
F	TR	SI SI
G	BP	SI NO (bloccata)
H	MP	SI NO (bloccata)
I	TR	SI NO (bloccata)

TARGHETTATURA	
A	ITALIANO / INGLESE
B	FRANCESE / SPAGNOLO
C	TEDESCO / GRECO

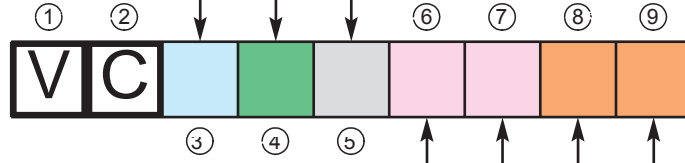

TARATURE (mbar) BP			
		Pdsu	Pdsu
		Max./Min.	Solo Max
A A	SENZA MOLLE		
A L	30	8	---
A Q	32	10	---
A E	43	6	43
A Y	43	10	---
C Y	45	10	---
D D	48	10	---
D G	50	10	50
D P	50	15	---
D S	60	10	---
E Q	70	10	70
D L	70	22	---
E C	75	30	---
E I	80	20	80
E J	80	30	---
E U	90	30	---
E V	100	10	100
E W	100	50	---
F G	110	30	---
F T	120	30	120
F R	120	10	---
F I	120	40	---
F Q	125	10	---
F P	125	20	---
G A	130	40	---
G B	140	30	140
G C	140	50	---
G D	150	10	---
G G	150	20	150
G U	160	60	---
H A	170	70	---
H B	180	60	---

TARATURE (mbar) MP			
		Pdsu	Pdsu
		Max./Min.	Solo Max.
G B	140	30	140
G C	140	50	---
G D	150	10	---
G G	150	20	150
G I	150	40	---
G Q	160	50	160
G U	160	60	---
H A	170	70	---
H B	180	60	---
H E	190	80	---
G V	200	65	200
G Z	200	70	---
G Y	200	80	---
G X	200	100	---
H U	210	90	---
H V	230	60	---
G S	250	10	---
H F	250	60	---
H G	250	70	250
H P	250	120	---
H J	300	60	---
H Q	300	120	---
H R	300	120	---
H T	350	150	---
H W	360	150	360
I E	360	240	---
H S	365	100	---
I B	400	60	---
H Y	400	200	---
H X	440	110	440
I A	440	180	---

TARATURE (mbar) TR			
		Pdsu	Pdsu
		Max./Min.	Solo Max
I A	440	180	---
K Z	480	340	---
I C	500	100	---
I I	520	250	---
I J	600	200	---
I F	750	100	---
I G	750	150	---
I H	800	200	---
I P	850	300	---
I M	900	250	---
I L	950	200	---
I N	1000	100	---
I Q	1000	200	1000
I K	1000	250	---
I U	1100	400	---
I V	1200	500	---
I T	1200	300	---
I R	1300	300	---
I S	1400	250	1400
J A	1400	600	---
J C	1450	350	---
I W	1500	400	1500
I X	1500	500	---
I Y	1600	600	---
J D	1700	500	---
K M	1750	600	---
J B	1800	500	---
J J	2000	100	---
J F	2000	400	2000
K T	2000	500	---
K W	2000	700	---
J H	2000	1000	---
J R	2400	1600	---
J E	2500	500	2500
J G	2500	1000	---
J U	3000	100	---
J K	3000	200	3000
J M	3000	700	---
J L	3000	1000	---
J S	3000	1500	---
J N	3200	1000	---
J P	3400	1000	---
J T	3600	1000	---
J W	4000	1000	4000
J X	4000	2000	---
J Y	4500	100	---
J Z	5000	300	5000
K A	5000	2500	---
K D	5400	3000	---

VERSIONE	
0 0	X FLUIDO G.N.
0 1	.
0 2	.
0 3	.
0 4	X FLUIDO OSSIGENO
0 5	.
0 6	00 + GUARNIZIONI IN VITON
0 7	.
0 8	00 + APPLICAZIONE MICRO
0 9	.
1 0	.
1 1	.
1 2	.
1 3	X FLUIDO AZOTO
1 4	.
1 5	.
1 6	X FLUIDO ARIA
1 7	X BIOGAS
1 8	.
1 9	.
2 0	.
2 1	00 + VITON + MICRO

\* = Standard test noktası  
Standard test bottom

Açıklama amaçlıdır.  
Tüm mümkün modelleri oluşturmak için lütfen aşağıdaki web sitesini deneyin:  
[www.fioxchange.com/Servizi Fiorentini](http://www.fioxchange.com/Servizi_Fiorentini)  
orada yukarıda yazan açıklamaların İngilizcesini de bulabilirsiniz.

This table is only demonstration.  
To create all allowable versions please refer to FM configurator on website:  
[www.fioxchange.com/Servizi Fiorentini](http://www.fioxchange.com/Servizi_Fiorentini)  
where you can also find english translation



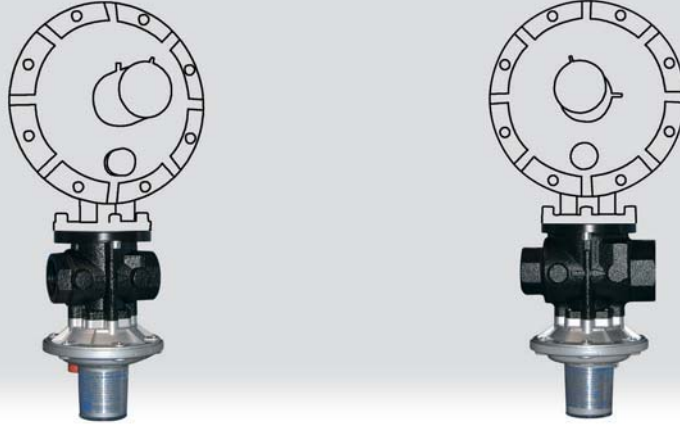

## GİRİŞ

LE kapatma vanası veya basınç switch vanası, LA kapatma vanası veya basınç switch vanası, tüm DIVAL 500 serisi regülatörlere uygulanabilen emniyet aygıtlarıdır. Kapama vanalarının amacı, herhangi bir tehlikeli durum oluşunca, gaz akışını kesmektir. Bu işlem, regülatörün ya da kapama aygıtının çıkışındaki bir noktadan ölçüm alınarak yapılır.

## INTRODUCTION

The mod. LE shut-off valve or pressure switch valve is a safety device which may be applied to the regulation equipment to all DIVAL 500 series regulators. The purpose of the shut-off valves is to interrupt the gas flow, through an external plug, each time a dangerous situation occurs. Their operation is sensed at a point downstream of the regulator or shut-off device. They are suitable for Natural gas, LPG and other non corrosive gases.

## TEMEL ÖZELLİKLER

- Sıcaklık sınıfı: 2 (-20°C + 60°C).
- Maksimum basınç: PS 10 bar.
- Yüksek giriş basınçlarında bile kolay resetlenme.
- Yalnızca elle resetlenebilir (sıcaklık artışı durumu hariç).
- Güvenlik klapesi kafada, böylelikle herhangi bir hasarda mühür kontrol edebilme imkanı..
- Giriş basıncını gövdeden kontrol edebilme

Aygıt şu durumlarda müdahale eder.:

- **YÜKSEK BASINÇ** – görüntülenen basıncın kalibre edilmiş değerinin üstüne çıkması durumunda. (kullanımdaki yayın sınırlarına göre kalibrasyon değişebilir).
- **ALÇAK BASINÇ** - görüntülenen basıncın kalibre edilmiş değerinin altına inmesi durumunda. (kullanımdaki yayın sınırlarına göre kalibrasyon değişebilir)

## MAIN FEATURES

- Temperature class: 2 (-20°C + 60°C); (-68°F + 140°F).
  - Maximum pressure: Ps 10 bar - Ps 145 Psi.
  - Easy resetting with high inlet pressures.
  - Manual reset only (except for the intervention in case of Temperature increase).
  - Security tab is included on the cap to enable checking the seal for any violation.
  - Inlet pressure to the valve is measured upstream.
- The device operates in the following cases:
- **OVER PRESSURE** - in case the monitoring pressure exceeds the calibration limits. (the calibration changes from the outside according to the range forecast by the spring in use).
  - **UNDER PRESSURE** - in case the monitoring pressure goes below the calibration limits (the calibration changes from the outside according to the range forecast by the spring in use).

97/23 CE PED DİREKTİFLERİNE UYGUN

CONFORMING TO THE 97/23 CE PED DIRECTIVE

ETIKET KODLAMASI  
T-00260 Mod. LE

LEGGENDA	
① ②	Sigla prodotto
③	Modello
④	Tipo di intervento
⑤	Targhettatura
⑥ ⑦	Tarature
⑧ ⑨	Versione
STD	Standard
G.N.	Gas Naturale
G.P.L.	Gas Petrolio Liquefatto
BP	Bassa Pressione
MP	Media Pressione
TR	Testata Ridotta (Alta Pressione)

MODELLO	
G.N. / G.P.L.	
A	x DIVAL 500 1"
B	x DIVAL 500 1"1/2
C	.
D	.
E	.
F	.
G	.
H	.

TIPO	BLOCCO	
	MAX	MIN
A	BP	SI NO (riattivabile)
B	BP	SI SI
C	MP	SI NO (riattivabile)
D	MP	SI SI
E	TR	SI NO (riattivabile)
F	TR	SI SI
G	BP	SI NO (bloccato)
H	MP	SI NO (bloccato)
I	TR	SI NO (bloccato)

TARGHETTATURA	
A	ITALIANO / INGLESE
B	FRANCESE / SPAGNOLO
C	TEDESCO / GRECO

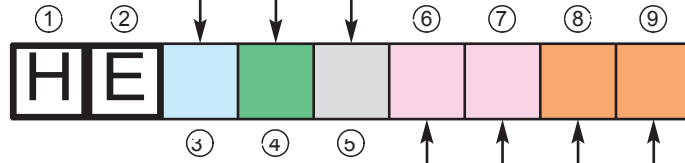

TARATURE (mbar) BP			
		Pdsu	Pdsu
		Max./Min.	Solo Max
SENZA MOLLE			
A	A	32	10
A	E	43	6
A	Y	43	10
C	Y	45	10
D	D	48	10
D	G	50	10
D	P	50	15
D	S	60	10
E	Q	70	10
D	L	70	22
E	C	75	30
E	I	80	20
E	J	80	30
E	U	90	30
E	V	100	10
E	W	100	50
F	G	110	30
F	T	120	30
F	R	120	10
F	I	120	40
F	Q	125	10
F	P	125	20
G	A	130	40
G	B	140	30
G	C	140	50
G	D	150	10
G	G	150	20
G	I	150	40
G	Q	160	50
G	U	160	60

TARATURE (mbar) MP			
		Pdsu	Pdsu
		Max./Min.	Solo Max.
H	E	190	80
G	Y	200	80
G	X	200	100
H	U	210	90
G	S	250	10
H	P	250	120
H	Q	300	120
H	R	300	120
H	T	350	150
H	W	360	150
I	E	360	240
H	S	365	100
I	B	400	60
H	Y	400	200
H	X	440	110
I	A	440	180

TARATURE (mbar) TR			
		Pdsu	Pdsu
		Max./Min.	Solo Max
I	A	440	180
K	Z	480	340
I	C	500	100
I	I	520	250
I	J	600	200
I	F	750	100
I	G	750	150
I	H	800	200
I	P	850	300
I	M	900	250
I	L	950	200
I	N	1000	100
I	Q	1000	200
I	K	1000	250
I	U	1100	400
I	V	1200	500
I	T	1200	300
I	R	1300	300
I	S	1400	250
J	A	1400	600
J	C	1450	350
I	W	1500	400
I	X	1500	500
I	Y	1600	600
J	D	1700	500
K	M	1750	600
J	B	1800	500
J	J	2000	100
J	F	2000	400
K	T	2000	500
K	W	2000	700
J	H	2000	1000
J	E	2500	500
J	G	2500	1000
J	U	3000	100
J	K	3000	200
J	M	3000	700
J	L	3000	1000
J	S	3000	1500

VERSIONE	
0 0	X FLUIDO G.N.
0 1	.
0 2	.
0 3	.
0 4	X FLUIDO OSSIGENO
0 5	.
0 6	00 + GUARNIZIONI IN VITON
0 7	.
0 8	.
0 9	.
1 0	00 + FOTO SFIATO SUPPLEM.
1 1	.
1 2	.
1 3	X FLUIDO AZOTO
1 4	.
1 5	.
1 6	X FLUIDO ARIA
1 7	X BIOGAS
1 8	.
1 9	.
2 0	.
2 1	00 + VITON + MICRO
W 0	00+PRESA DI PRESS. EST. ATT.
W B	00+PRESA DI PRESS. EST. ATT.

Açıklama amaçlıdır.  
Tüm mümkün modelleri oluşturmak için lütfen aşağıdaki web sitesini deneyin:  
[www.fioxchange.com/Servizi Fiorentini](http://www.fioxchange.com/Servizi_Fiorentini)  
orada yukarıda yazan açıklamaların İngilizcesini de bulabilirsiniz.

This table is only demonstration.  
To create all allowable versions please refer to FM configurator on website:  
[www.fioxchange.com/Servizi Fiorentini](http://www.fioxchange.com/Servizi_Fiorentini)  
where you can also find english translation

