

## RS 310-410-510-610/E-EV MZ SERIES

The RS 310-410-510-610/E-EV MZ burners series covers a firing range from 1300 to 6300 kW, and it has been designed for use in low or medium temperature hot water boilers, hot air or steam boilers, diathermic oil boilers.

It is based on the Digital Burner Management System, Riello REC27-37, which is able to manage the air-fuel ratio by independent servomotors in order to obtain a perfect output control and to assure a correct combustion and safe operation on all modulation range. Operation can be "two stage progressive" or, alternatively, "modulating" with the installation of a PID logic regulator and respective probes. RS/E-EV MZ burners series guarantees high efficiency levels in all the various applications, thus reducing fuel consumption and running costs; specific versions are available to operate with Variable Speed Drive technology base on the control of a Frequency Inverter that modifies the air flow through the motor speed variation.

The exclusive design ensures reduced dimensions, simple use and maintenance.

A wide range of accessories guarantees elevated working flexibility.



RS 310/E-EV MZ	600/1300 ÷ 3900 kW
RS 410/E-EV MZ	800/2000 ÷ 4900 kW
RS 510/E-EV MZ	800/2200 ÷ 5520 kW
RS 610/E-EV MZ	820/2400 ÷ 6300 kW

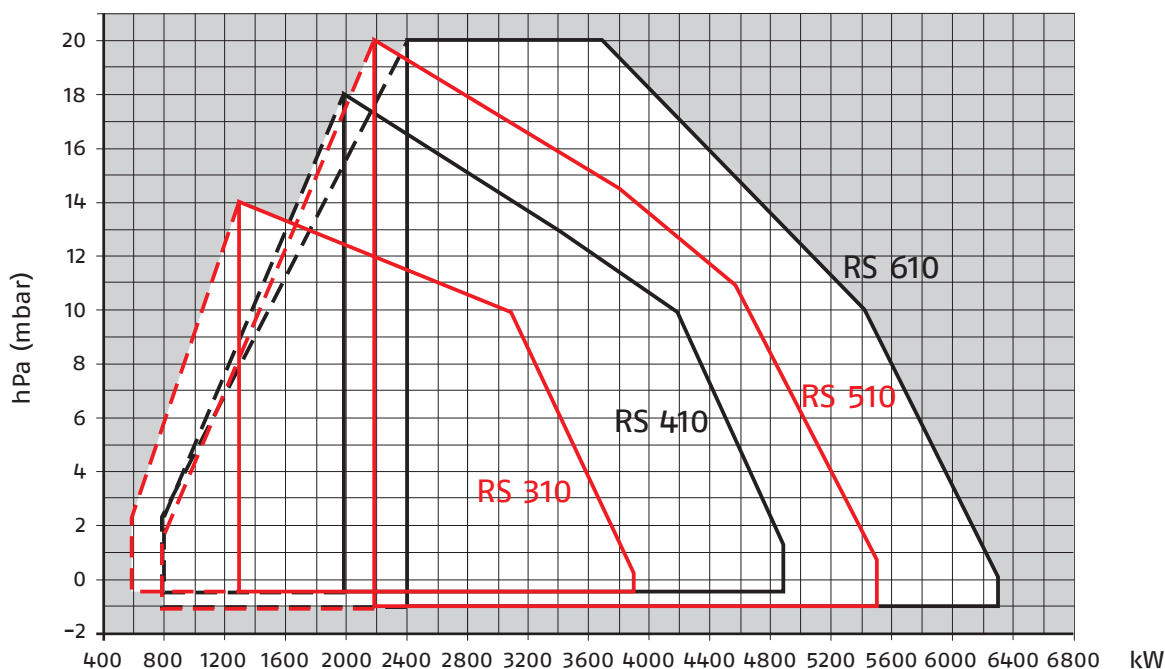

□ Useful working field for choosing the burner

▭ Modulation range

Test conditions conforming to EN676  
 Temperature: 20°C  
 Pressure: 1013,5 mbar  
 Altitude: 0 m a.s.l.

# Modulating Gas Burners

## RS 310-410-510-610/E-EV MZ SERIES

### Overall dimensions (mm)

#### BURNERS

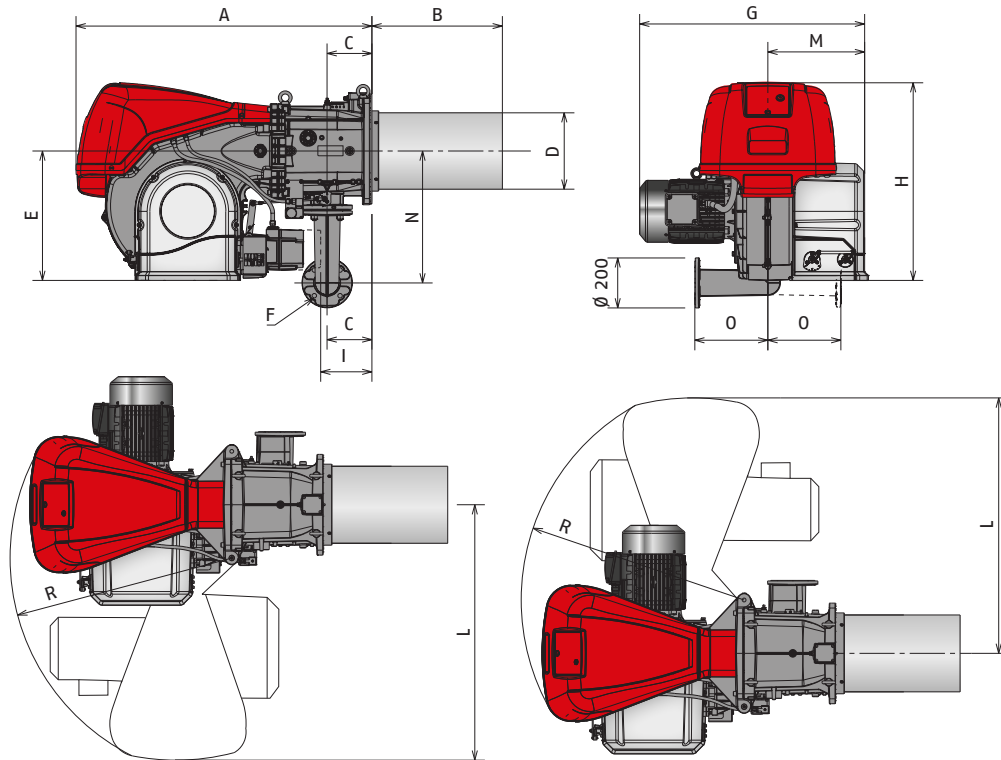

Model	A	B	C	D	E	F	G	H	I*	L	M	N	O	P	R
▶ RS 310/E-EV MZ	1178	519	178	306	520	DN65	890	790	177	1015	400	528	290	177	890
▶ RS 410/E-EV MZ	1178	519	178	306	520	DN65	908	790	177	1015	400	528	290	177	890
▶ RS 510/E-EV MZ	1178	519	178	306	520	DN65	908	790	177	1015	400	528	290	177	890
▶ RS 610/E-EV MZ	1178	519	178	330	520	DN65	980	790	177	1015	400	528	290	177	890

\* Maximum position for the extraction of the servomotor cover in mechanical cam models.

#### BURNER - BOILER MOUNTING FLANGE

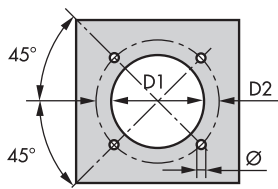

Model	D1	D2	Ø
▶ RS 310/E-EV	335	452	M18
▶ RS 410/E-EV	335	452	M18
▶ RS 510/E-EV	335	452	M18
▶ RS 610/E-EV	350	452	M18

#### PACKAGING

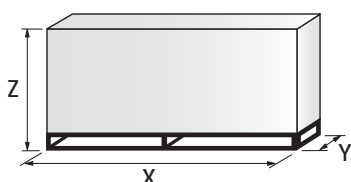

Model	X	Y	Z	kg
▶ RS 310/E-EV	2040	1180	1125	250
▶ RS 410/E-EV	2040	1180	1125	250
▶ RS 510/E-EV	2040	1180	1125	250
▶ RS 610/E-EV	2040	1180	1125	250

## RS 310-410-510-610/E-EV MZ SERIES

### Specification

#### DESIGNATION OF SERIES

A specific index guides your choice of burner from the various models available in the RS/M MZ series. Below is a clear and detailed specification description of the product.

Series: R											
Fuel: S Natural Gas											
L Light oil											
LS Light oil/Natural Gas											
N Heavy oil											
Size:											
Setting: /1 Single stage											
/B Two stage											
/M Modulating-Mechanical cam											
/E Electronic cam											
/P Proportioning air/gas valve											
/EV Electronic cam predisposed for variable speed (with inverter)											
/EVi Electronic cam with integrated inverter											
Emission: ... or C01 Class 1 EN676											
MZ Class 2 EN676											
BLU Class 3 EN676											
MX Class 3 EN676											
Head length: TC standard head											
TL extended head											
Flame control system: FS1 Standard/Intermittent (at least 1 stop every 24 h)											
FS2 Continuous (1 stop every 72 h)											
Electrical supply to the system:											
1/230/50					1/230V/50Hz						
3/230/50					3/230V/50Hz						
3/400/50					3N/400V/50Hz						
3/230-400/50					3/230V/50Hz - 3N/400V/50Hz						
3/220/60					3/220V/60Hz						
3/380/60					3N/380V/60Hz						
3/220-380/60					3/220/60Hz - 3N/380V/60Hz						
Auxiliary voltage: 230/50-60 230V/50-60H											
110/50-60 110V/50-60Hz											
R	S	510	/E	MZ	TC	FS1	3/230-400/50	230/50-60			
BASIC DESIGNATION								EXTENDED DESIGNATION			

### Specification

#### STATE OF SUPPLY

Monoblock forced draught burners with two stage progressive or modulating operation, with a specific kit, fully automatic, made up of:

- Microprocessor-based Digital Burner Management System (RS/E MZ models)
- Microprocessor-based Digital Burner Management System with Variable Speed Drive technology for the control of a Frequency Inverter (RS/EV MZ models)
- Display Interface operating unit to adjust the system
- Air suction circuit lined with sound-proofing material
- High performance fan with low sound emissions, forward curve blades
- Air damper for air flow setting and butterfly valve for regulating fuel output controlled by independent stepper motor actuators
- Air pressure switch
- Fan starting motor at 2900 rpm, three-phase 230/400 - 400/690 V with neutral, 50 Hz
- Combustion head, that can be set on the basis of required output, fitted with:
  - stainless steel end cone, resistant to corrosion and high temperatures
  - ignition electrodes; ionisation sensor for flame detection (or UV sensor on demand)
  - flame stability disk
- Maximum gas pressure switch, with pressure test point, for halting the burner in the case of over pressure on the fuel supply line
- Star/delta starter for the fan motor (Direct starter fan motor for RS 310-410 models)
- Main electrical supply terminal board
- Burner on/off switch
- Manual or automatic output increase/decrease switch
- Contacts motor and thermal relay with release button
- Burner failure led signal and lighted release button
- Burner opening hinge
- Lifting rings
- IP 54 electric protection level

#### Standard equipment:

Gasket for gas train adaptor

Adaptor for gas train

Screws for fixing the gas train adaptor: M 16 x 70

Thermal insulation screen

M 18 x 60 screws to secure the burner flange to the boiler

Cable grommets kit for optional electrical wiring input

M16 x 6 studs for fixing the gas elbow to the pipe coupling

M16 nuts to fix the gas elbow to the pipe coupling

Instruction handbook for installation, use and maintenance

Spare parts catalogue

#### Gas train

Fuel supply line, in the MULTIBLOC configuration (for a diameter of 1-1/2" and 2") or COMPOSED configuration (from a diameter of DN 65 until a diameter of DN 125), fitted with:

- Filter
- Stabiliser
- Minimum gas pressure switch
- Safety valve
- One stage working valve with ignition gas output regulator.

## RS 310-410-510-610/E-EV MZ SERIES

### Specification

**Conforming to:**

- 2014/30/EU directive (electromagnetic compatibility)
- 2014/35/EU directive (low voltage)
- 2016/426/EU gas regulation (GAR)
- 2006/42 CE directive (machine)
- EN 676 (gas burners).

**Available accessories to be ordered separately:**

- Power controller
- Probe
- Continuous ventilation kit
- UV cell kit
- Variable speed drive (VSD) kit (for RS/EV series only)
- PC interface kit
- OCI412 Interface kit
- Sound proofing box
- Spacer kit
- Adapters
- PVP (Pressure Proving System)
- Stabiliser spring.

# Modulating Gas Burners

## RS 310-410-510-610/E-EV MZ SERIES

### Available models

#### Burners

CODE	MODEL				HEAT OUTPUT		TOTAL ELECTRICAL POWER (KW)	CERTIFICATION	NOTE
					NATURAL GAS				
					(KW)	(Nm <sup>3</sup> /h)			
20068349	RS 310/E MZ	TC	FS1	3/230/50	600/1300-3900	40/120-363	9,1	CE-0085CP0166	
20068353	RS 310/E MZ	TC	FS1	3/400/50	600/1300-3900	40/120-363	9,1	CE-0085CP0166	
20068026	RS 310/E MZ	TC	FS1	3/400/50	600/1300-3900	40/120-363	8,8	CE-0085CP0166	(1)
20074260	RS 310/E MZ	TC	FS2	3/230/50	600/1300-3900	40/120-363	8,8	CE-0085CP0166	
20074261	RS 310/E MZ	TC	FS2	3/400/50	600/1300-3900	40/120-363	9,1	CE-0085CP0166	
20074264	RS 310/E MZ	TC	FS2	3/400/50	600/1300-3900	40/120-363	9,1	CE-0085CP0166	(1)
20068358	RS 410/E MZ	TC	FS1	3/230/50	800/2000-4900	50/150-445	10,6	CE-0085CP0166	
20068363	RS 410/E MZ	TC	FS1	3/400/50	800/2000-4900	50/150-445	10,6	CE-0085CP0166	
20067961	RS 410/E MZ	TC	FS1	3/400/50	800/2000-4900	50/150-445	10,6	CE-0085CP0166	(1)
20074262	RS 410/E MZ	TC	FS2	3/230/50	800/2000-4900	50/150-445	10,6	CE-0085CP0166	
20074263	RS 410/E MZ	TC	FS2	3/400/50	800/2000-4900	50/150-445	10,6	CE-0085CP0166	
20074265	RS 410/E MZ	TC	FS2	3/400/50	800/2000-4900	50/150-445	10,6	CE-0085CP0166	(1)
20068028	RS 510/E MZ	TC	FS1	3/400/50	800/2200-5520	68/180-525	13,9	CE-0085CP0166	(1)
20074266	RS 510/E MZ	TC	FS2	3/400/50	800/2200-5520	68/180-525	13,9	CE-0085CP0166	(1)
20067963	RS 610/E MZ	TC	FS1	3/400/50	820/2400-6300	100/220-625	16,9	CE-0085CP0166	(1)
20074267	RS 610/E MZ	TC	FS2	3/400/50	820/2400-6300	100/220-625	16,9	CE-0085CP0166	(1)
20074274	RS 310/EV MZ	TC	FS1/FS2	3/230/50	600/1300-3900	40/120-363	9,1	CE-0085CP0166	
20074275	RS 310/EV MZ	TC	FS1/FS2	3/400/50	600/1300-3900	40/120-363	9,1	CE-0085CP0166	
20074276	RS 410/EV MZ	TC	FS1/FS2	3/230/50	800/2000-4900	50/150-445	10,8	CE-0085CP0166	
20074277	RS 410/EV MZ	TC	FS1/FS2	3/400/50	800/2000-4900	50/150-445	10,8	CE-0085CP0166	
20074278	RS 510/EV MZ	TC	FS1/FS2	3/400/50	800/2200-5520	68/180-525	14	CE-0085CP0166	
20074279	RS 610/EV MZ	TC	FS1/FS2	3/400/50	820/2400-6300	100/220-625	17	CE-0085CP0166	

Natural gas, net calorific value: 10 kWh/Nm<sup>3</sup> - Density: 0,71 kg/Nm<sup>3</sup>

The burners of RS/E-EV MZ series are in according to 2016/426/EU - 2014/30/EU - 2014/35/EU - 2014/68/EU - 2006/42 CE Directives.

(1) Star delta starter

## RS 310-410-510-610/E-EV MZ SERIES

### Available models

#### Gas Trains

CODE	GAS TRAIN MODEL	∅	ADAPTER CODE			
			RS 310	RS 410	RS 510	RS 610
3970250*	MB 415/1 - RT 52	Rp 1" 1/2	3000826 + 20064220	●	●	●
3970257*	MB 420/1 - RT 52	Rp 2"	3000826 + 20042324	●	●	●
20137718*	VGD 50/1 - RT 122 (1)	Rp 2"	(3000826 + 20042324) / 20068062 (3)			●
20140762*	VGD 65/1 - FT 122	DN 65 (2)	□			
20140763*	VGD 80/1 - FT 122	DN 80	□			
20169193*	VGD 100/1 - FT 122	DN 100	3010370			
20169195*	VGD 125/1 - FT 122	DN 125	3010224			

Please see designation of Gas Train Series in the page before the Catalogue index.

\* 230V/50Hz -220V/60Hz electrical supply.

\*\* 230V/50Hz electrical supply.

The valves seal control device is compulsory (conforming to EN 676) on gas trains to burners with a maximum output over 1200 kW.

The seal control function is managed by REC control box, by installation on gas train of a pressure switch (please see Gas train accessories paragraph).

To select the gas train please refer to the technical data leaflet and/or instruction manual.

(1) Additional flange kit code 20185515 needed for seal control function.

(2) ∅in = DN 65, ∅out = DN 80.

(3) To be used with gas train and burner opening on the left (fan motor side).

● Not available.

□ Additional adapter not necessary, the gas train may be connected directly to the burner.

# Modulating Gas Burners

## RS 310-410-510-610/E-EV MZ SERIES

### Burner accessories

#### Accessories for modulating operation

##### POWER CONTROLLER



To obtain modulating operation, the RS/E-EV MZ series of burners requires a regulator with three point outlet controls. The following table lists the accessories for modulating operation with their application range. For remote setpoint use RWF 55.

BURNER	TYPE	KIT CODE
▶ All models	RWF 50.2 - Basic version with 3 position output	20073595
	RWF 55.5 - Complete with RS-485 interface	20074441
	RWF 55.6 - Complete with RS-485/ PROFIBUS interface	20074442

##### PROBE



The relative temperature or pressure probes fitted to the power controller must be chosen on the basis of the application.

BURNER	TYPE	RANGE (°C) (BAR)	KIT CODE
▶ All models	Temperature PT 100	-100 ÷ 500°C	3010110
	Pressure 4 ÷ 20 mA	0 ÷ 2,5 bar	3010213
	Pressure 4 ÷ 20 mA	0 ÷ 16 bar	3010214
	Pressure 4 ÷ 20 mA	0 ÷ 25 bar	3090873

#### Continuous ventilation kit



If the burner requires continuous ventilation in the stages without flame, a special kit is available as given in the following table:

BURNER	KIT CODE
▶ RS 310-410-510-610/E	20074542

#### Pc interface kit



To connect the control panel to a personal computer for the transmission of operation, fault signals and detailed service information, an interface adapter with PC software are available.

BURNER	KIT CODE
▶ RS 310-410-510-610/E-EV (ACS410 + OCI410.30) - Service level	3010436



## RS 310-410-510-610/E-EV MZ SERIES

### Burner accessories

#### Variable Speed Drive (VSD) for RS/EV series only



The motor speed variation for the RS/EV BLU burners series is obtained thanks to a frequency converter: variable speed drive (VSD), provided with a programming panel with start-up assistant. It always must be ordered with RS/EV series.

BURNER	ELECTRICAL SUPPLY	MOTOR POWER (kW)	INVERTER POWER (kW)	KIT CODE
▶ RS 310/EV	230	7,5	7,5	On demand
▶ RS 310/EV	400	7,5	7,5	20163074
▶ RS 410/EV	230	9,2	11	20184963
▶ RS 410/EV	400	9,2	11	20163093
▶ RS 510/EV	400	12	15	20163096
▶ RS 610/EV	400	15	15	20163096

The use of inverters other than those indicated by the manufacturer may lead to burner failure and, in extreme cases, a potential risk of harm to people and damage to property. The manufacturing company shall not be liable for any such damage arising from non-observance of the requirements contained in the burner manual.

#### OCI412 interface kit



Interface kit between the REC 27.1 and a Modbus system, such as a building automation and control system (BACS). The Modbus interface is based on the RS-485 standard.

BURNER	KIT CODE
▶ RS 310-410-510-610/E-EV	3010437

#### Sound proofing box

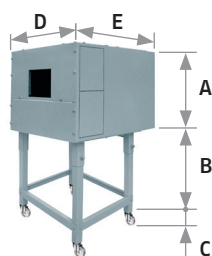

If noise emission needs reducing even further, sound-proofing boxes are available.

When a lower "B" dimension is required, it is available the Box Support Kit code 20065135 which allows to reduce it at the fixed dimension of 55 mm.

The sound-proofing boxes are not suitable for outdoor use.

BURNER	BOX TYPE	A (mm)	B (mm) min. - max	C (mm)	D (mm)	E (mm)	[dB(A)] (*)	KIT CODE
▶ RS 310-410/E-EV	C7	1255	160 - 980	110	1140	1345	10	3010376
▶ RS 610/E-EV	C7 PLUS	1255	270 - 1090	110	1240	1345	10	20085111
▶ RS 310-410/E-EV RS510/E-EV	C7	1255	165	110	1140	1345	10	20027778

(\*) Average noise reduction according to EN 15036-1 standard

#### Spacer kit

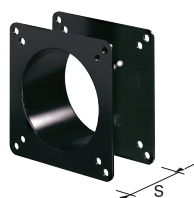







If burner head penetration into the combustion chamber needs reducing, varying thickness spacers are available, as given in the following table:

BURNER	Spacer thickness S (mm)	KIT CODE
▶ All models	180	20008903

### Gas train accessories

#### Adapters

In certain cases, an adapter must be fitted between the gas train and the burner, when the diameter of the gas train is different from the set diameter of the burner. Below are given the available adapters; please see on the Gas Train list the correct adapter codes to select.

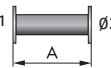
ADAPTER	DIMENSIONS		ADAPTER CODE		
	ø1 DN	ø2 DN		A mm	B mm
1" 1/2  2"	-	-	65	-	20064220
2"  2"	-	-	65	-	20042324
DN 80  2" 1/2  2"	-	-	300	-	3000826
DN 100  DN 80	100	80	50	-	3010370
DN 80/65  2"	2"	65/80	780	230	20068062
	125	80	320	-	3010224

#### PVP (pressure valve proving kit)\*

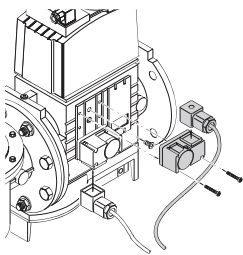

The seal control function is included on Burner Digital Management System, it is only necessary to add the PVP kit on the gas train.

GAS TRAIN	KIT CODE
► All MB models, VGD 65/1 - 80/1 - 100/1 - 125/1	3010344
► VGD 50/1	3010344 + 20185515

#### Stabiliser spring



To vary the pressure range of the gas train stabilisers, accessory springs are available. The following table shows these accessories with their application range. Please refer to the technical manual for the correct choice of spring.

GAS TRAIN	SPRING COLOUR	SPRING PRESSURE RANGE mbar	SPRING CODE
► VGD/1 series	Neutral	0 - 22	20181839
	Yellow	15 - 120	20141900
	Red	100 - 250	20141901