

RS 310-410-510-610/M MZ SERIES

The RS 310-410-510-610/M MZ burners series covers a firing range from 1300 to 6300 kW, and it has been designed for use in low or medium temperature hot water boilers, hot air or steam boilers, diathermic oil boilers.

Operation can be "two stage progressive" or, alternatively, "modulating" with the installation of a PID logic regulator or by external 4-20 mA/0-10 V signal.

The mechanical cam device of regulation allows to catch up a high modulation ratio on all firing rates range. The burners can, therefore, supply with precision the demanded power, guaranteeing a high efficiency system level and the stability setting, obtaining fuel consumption and operating costs reduction.

FS1 and FS2 versions are available for intermittent and continuous operation applications.

The exclusive design ensures reduced dimensions, simple use and maintenance.

A wide range of accessories guarantees elevated working flexibility.



RS 310/M MZ	600/1300 ÷ 3900	kW
RS 410/M MZ	800/2000 ÷ 4900	kW
RS 510/M MZ	800/2200 ÷ 5520	kW
RS 610/M MZ	820/2400 ÷ 6300	kW

GAS

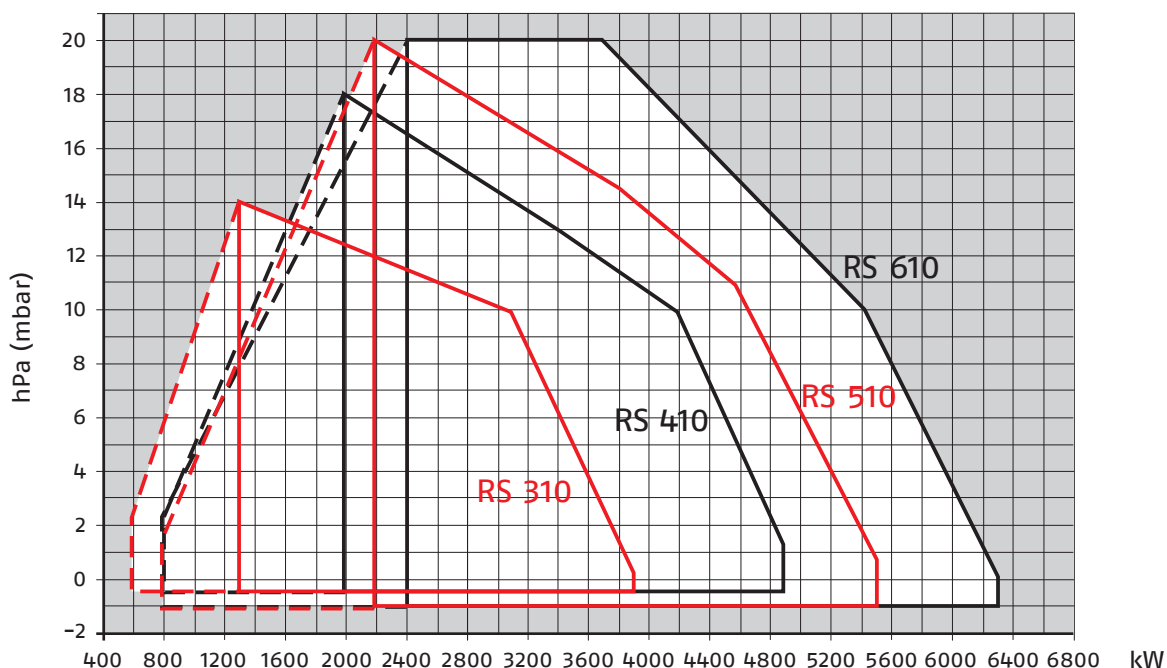

Modulating Gas Burners

RS 310-410-510-610/M MZ SERIES

Overall dimensions (mm)

BURNERS

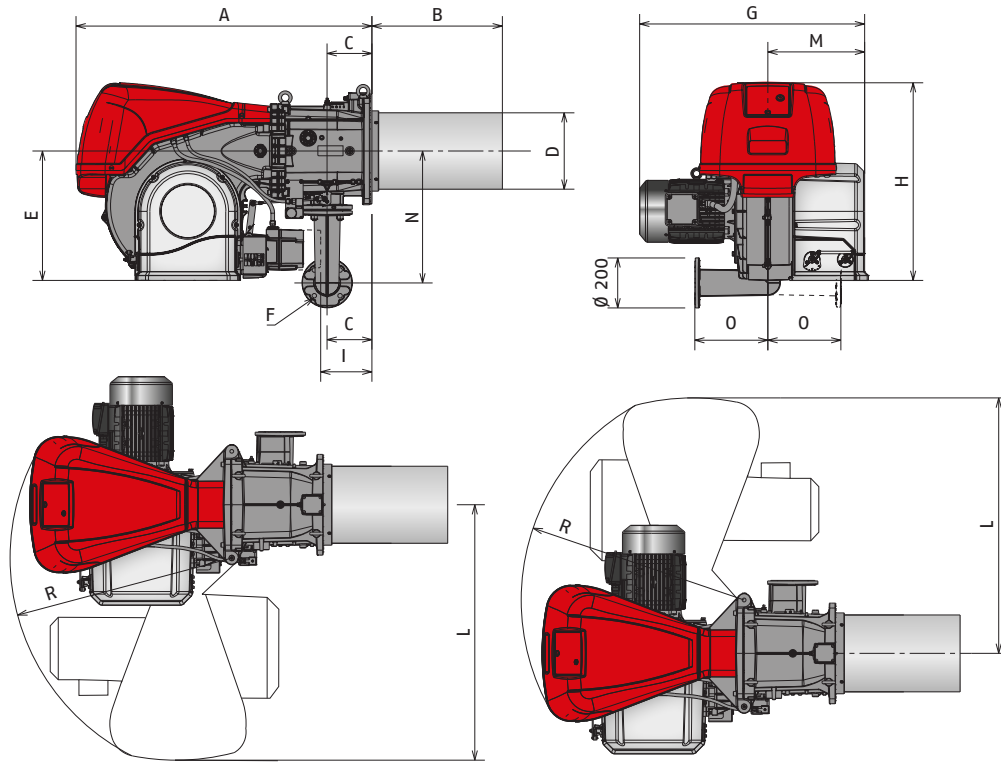

Model	A	B	C	D	E	F	G	H	I*	L	M	N	O	P	R
▶ RS 310/M MZ	1178	519	178	306	520	DN65	890	790	177	1015	400	528	290	177	890
▶ RS 410/M MZ	1178	519	178	306	520	DN65	908	790	177	1015	400	528	290	177	890
▶ RS 510/M MZ	1178	519	178	306	520	DN65	908	790	177	1015	400	528	290	177	890
▶ RS 610/M MZ	1178	519	178	330	520	DN65	980	790	177	1015	400	528	290	177	890

* Maximum position for the extraction of the servomotor cover in mechanical cam models.

BURNER - BOILER MOUNTING FLANGE

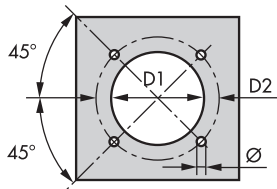

Model	D1	D2	Ø
▶ RS 310/M MZ	335	452	M18
▶ RS 410/M MZ	335	452	M18
▶ RS 510/M MZ	335	452	M18
▶ RS 610/M MZ	350	452	M18

PACKAGING

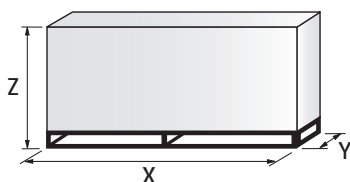

Model	X	Y	Z	kg
▶ RS 310/M MZ	2040	1180	1125	250
▶ RS 410/M MZ	2040	1180	1125	250
▶ RS 510/M MZ	2040	1180	1125	250
▶ RS 610/M MZ	2040	1180	1125	280

RS 310-410-510-610/M MZ SERIES

Specification

DESIGNATION OF SERIES

A specific index guides your choice of burner from the various models available in the RS/M MZ series. Below is a clear and detailed specification description of the product.

Series: R									
Fuel: S Natural Gas									
L Light oil									
LS Light oil/Natural Gas									
N Heavy oil									
Size:									
Setting: /1 Single stage									
/B Two stage									
/M Modulating-Mechanical cam									
/E Electronic cam									
/P Proportioning air/gas valve									
/EV Electronic cam predisposed for variable speed (with inverter)									
/EVi Electronic cam with integrated inverter									
Emission: ... or C01 Class 1 EN676									
MZ Class 2 EN676									
BLU Class 3 EN676									
MX Class 3 EN676									
Head length: TC standard head									
TL extended head									
Flame control system: FS1 Standard/Intermittent (at least 1 stop every 24 h)									
FS2 Continuous (1 stop every 72 h)									
Electrical supply to the system:									
1/230/50					1/230V/50Hz				
3/230/50					3/230V/50Hz				
3/400/50					3N/400V/50Hz				
3/230-400/50					3/230V/50Hz - 3N/400V/50Hz				
3/220/60					3/220V/60Hz				
3/380/60					3N/380V/60Hz				
3/220-380/60					3/220/60Hz - 3N/380V/60Hz				
Auxiliary voltage: 230/50-60 230V/50-60H									
110/50-60 110V/50-60Hz									
R	S	510	/M	MZ	TC	FS1	3/230-400/50	230/50-60	
BASIC DESIGNATION									
EXTENDED DESIGNATION									

Specification

STATE OF SUPPLY

Monoblock forced draught gas burners with modulating operation, fully automatic, made up of:

- High performance fan with low sound emissions, forward curve blades.
- Air suction circuit lined with sound-proofing material
- Air damper for air setting controlled by a high precision servomotor
- Air pressure switch
- Fan starting motor at 2900 rpm, three-phase 230/400 - 400/690 V with neutral, 50 Hz
- Combustion head, that can be set on the basis of required output, fitted with:
 - stainless steel end cone, resistant to corrosion and high temperatures
 - ignition electrodes; ionisation sensor for flame detection
 - flame stability disk
- Maximum gas pressure switch, with pressure test point, for halting the burner in the case of over pressure on the fuel supply line
- Burner safety control box for controlling the system safety: RMG/M and RFG0 for FS1 intermittent operation and LGK for FS2 continuous operation for RS 310-410-510-610/M models;
- Star/delta starter for the fan motor (Direct starter fan motor for RS 310-410 models)
- Main electrical supply terminal board
- Burner on/off switch
- Manual or automatic output increase/decrease switch
- Contacts motor and thermal relay with release button
- Burner failure led signal and lighted release button
- Burner opening hinge
- Lifting rings
- IP 54 electric protection level

Standard equipment:

Gasket for gas train adaptor

Adaptor for gas train

Screws for fixing the gas train adaptor: M 16 x 70

Thermal insulation screen

M 18 x 60 screws to secure the burner flange to the boiler

Cable grommets kit for optional electrical wiring input

M16 x 6 studs for fixing the gas elbow to the pipe coupling

M16 nuts to fix the gas elbow to the pipe coupling

Instruction handbook for installation, use and maintenance

Spare parts catalogue

Gas train

Fuel supply line, in the MULTIBLOC configuration (for a diameter of 1-1/2" and 2") or COMPOSED configuration (from a diameter of DN 65 until a diameter of DN 125), fitted with:

- Filter
- Stabiliser
- Minimum gas pressure switch
- Safety valve
- One stage working valve with ignition gas output regulator.

RS 310-410-510-610/M MZ SERIES

Specification

Conforming to:

- 2014/30/EU directive (electromagnetic compatibility)
- 2014/35/EU directive (low voltage)
- 2016/426/EU gas regulation (GAR)
- 2006/42 CE directive (machine)
- EN 676 (gas burners).

Available accessories to be ordered separately:

- Power controller
- Probe
- Analog control signal converter
- Potentiometer
- Continuous ventilation kit
- PC interface kit
- Sound proofing box
- Spacer kit
- Adapters
- Seal Control kit
- Stabiliser spring.

Modulating Gas Burners

RS 310-410-510-610/M MZ SERIES

Available models

Burners

CODE	MODEL				HEAT OUTPUT		TOTAL ELECTRICAL POWER (KW)	CERTIFICATION	NOTE
					NATURAL GAS				
					(KW)	(Nm ³ /h)			
20061373	RS 310/M MZ	TC	FS1	3/400/50	600/1300-3900	60/130-390	8,8	CE-0085CP0166	(1) (4)
20068343	RS 310/M MZ	TC	FS1	3/230/50	600/1300-3900	60/130-390	9,1	CE-0085CP0166	(1)
20068351	RS 310/M MZ	TC	FS1	3/400/50	600/1300-3900	60/130-390	9,1	CE-0085CP0166	(1)
20152665	RS 310/M MZ	TC	FS1/FS2	3/400/50	600/1300-3900	60/130-390	9,1	CE-0085CP0166	(2)(4)(3)
20152658	RS 310/M MZ	TC	FS1/FS2	3/230/50	600/1300-3900	60/130-390	9,1	CE-0085CP0166	(2)(3)
20152661	RS 310/M MZ	TC	FS1/FS2	3/400/50	600/1300-3900	60/130-390	9,1	CE-0085CP0166	(2)(3)
20067141	RS 410/M MZ	TC	FS1	3/400/50	800/2000-4900	80/200-490	10,6	CE-0085CP0166	(1)(4)
20068356	RS 410/M MZ	TC	FS1	3/230/50	800/2000-4900	80/200-490	10,8	CE-0085CP0166	(1)
20068361	RS 410/M MZ	TC	FS1	3/400/50	800/2000-4900	80/200-490	10,8	CE-0085CP0166	(1)
20152669	RS 410/M MZ	TC	FS1/FS2	3/400/50	800/2000-4900	80/200-490	10,8	CE-0085CP0166	(2)(4)(3)
20152662	RS 410/M MZ	TC	FS1/FS2	3/230/50	800/2000-4900	80/200-490	10,8	CE-0085CP0166	(2)(3)
20152664	RS 410/M MZ	TC	FS1/FS2	3/400/50	800/2000-4900	80/200-490	10,8	CE-0085CP0166	(2)(3)
20068027	RS 510/M MZ	TC	FS1	3/400/50	800/2200-5520	80.2/220-552	14	CE-0085CP0166	(1)(4)
20152671	RS 510/M MZ	TC	FS1/FS2	3/400/50	800/2200-5520	80.2/220-552	14	CE-0085CP0166	(2)(4)
20066706	RS 610/M MZ	TC	FS1	3/400/50	820/2400-6300	82/240-630	16,9	CE-0085CP0166	(1)(4)
20152672	RS 610/M MZ	TC	FS1/FS2	3/400/50	820/2400-6300	82/240-630	16,9	CE-0085CP0166	(2)(4)(3)

Natural gas, net calorific value: 10 kWh/Nm³ - Density: 0,71 kg/Nm³

The burners of RS/M MZ series are in according to 2016/426/EU - 2014/30/EU - 2014/35/EU - 2006/42 CE Directives.

- (1) with RMG control box
- (2) with RFG0 control box
- (3) FS2 operation is allowed with ionization probe only, no other flame sensors can be used
- (4) Star delta starter
- (5) LFL control box

Due to the improvement of the technical specification of some products, some burner codes have been changed. The table below summarizes the correspondence between the previous and the new code.

MODEL				NEW CODE		OLD CODE	
RS 310/M MZ	TC	FS1/FS2	3/230/50	20152658	(2)(3)	20074137	(5)
RS 310/M MZ	TC	FS1/FS2	3/400/50	20152661	(2)(3)	20074138	(5)
RS 310/M MZ	TC	FS1/FS2	3/400/50	20152665	(2)(3)	20074141	(5)
RS 410/M MZ	TC	FS1/FS2	3/230/50	20152662	(2)(3)	20074139	(5)
RS 410/M MZ	TC	FS1/FS2	3/400/50	20152664	(2)(3)	20074140	(5)
RS 410/M MZ	TC	FS1/FS2	3/400/50	20152669	(2)(3)	20074142	(5)
RS 510/M MZ	TC	FS1/FS2	3/400/50	20152671	(2)(3)	20074143	(5)
RS 610/M MZ	TC	FS1/FS2	3/400/50	20152672	(2)(3)	20074144	(5)

RS 310-410-510-610/M MZ SERIES

Available models

Gas Trains

CODE	GAS TRAIN			VPS Code	ADAPTER CODE			
	MODEL	∅	C.T.		RS 310	RS 410	RS 510	RS 610
3970180*	MB 415/1 - RT 30	Rp 1" 1/2	-	3010123	3000826 + 20064220	●	●	●
3970198**	MB 415/1 CT RT 30	Rp 1" 1/2	◆	-		●	●	●
3970250*	MB 415/1 - RT 52	Rp 1" 1/2	-	3010123		●	●	●
3970253**	MB 415/1 CT RT 52	Rp 1" 1/2	◆	-		●	●	●
3970232*	MB 415/1 - RSM 30	Rp 1" 1/2	-	3010123	3000826 + 20042324	●	●	●
3970181*	MB 420/1 - RT 30	Rp 2"	-	3010123		●	●	●
3970182**	MB 420/1 CT RT 30	Rp 2"	◆	-		●	●	●
3970257*	MB 420/1 - RT 52	Rp 2"	-	3010123		●	●	●
3970252**	MB 420/1 CT RT 52	Rp 2"	◆	-		●	●	●
3970233*	MB 420/1 - RSM 30	Rp 2"	-	3010123		●	●	●
3970234**	MB 420/1 CT RSM 30	Rp 2"	◆	-		●	●	●
20137718*	VGD 50/1 - RT 122	Rp 2"	-	3010123+ 20186306		(3000826 + 20042324) / 20068062 (2)		
20169190**	VGD 50/1 CT RT 122	Rp 2"	◆	◆	(3000826 + 20042324) / 20068062 (2)			●
20140762*	VGD 65/1 - FT 122	DN 65 (1)	-	3010123	□			
20169191**	VGD 65/1 CT FT 122	DN 65 (1)	◆	◆	□			
20140763*	VGD 80/1 - FT 122	DN 80	-	3010123	□			
20169192**	VGD 80/1 CT FT 122	DN 80	◆	◆	□			
20169193*	VGD 100/1 - FT 122	DN 100	-	3010123	3010370			
20169194**	VGD 100/1 CT FT 122	DN 100	◆	◆	3010370			
20169195*	VGD 125/1 - FT 122	DN 125	-	3010123	3010224			
20169196**	VGD 125/1 CT FT 122	DN 125	◆	◆	3010224			

Please see designation of Gas Train Series in the page before the Catalogue index.

* 230V/50Hz - 220V/60Hz electrical supply.

** 230V/50Hz electrical supply.

The valve seal control device is compulsory (conforming to EN 676) on gas trains to burners with a maximum output over 1200 kW.

To select the gas train please refer to the technical data leaflet and/or instruction manual.

(1) ∅in = DN 65, ∅out = DN 80

(2) To be used with gas train and burner opening on the left (fan motor side).

C.T. Gas valve leak detection control device:

- gas train not equipped with leak detection control device; this device can be ordered separately - see VPS column - and installed later.

◆ gas train equipped with leak detection control device.

VPS Valve leak detection control device. Supplied separately from the gas train (please see Gas train accessories paragraph for both 50 Hz and 60 Hz codes).

● Not available.

□ Additional adapter not necessary, the gas train may be connected directly to the burner.

Modulating Gas Burners

RS 310-410-510-610/M MZ SERIES

Burner accessories

Accessories for modulating operation

POWER CONTROLLER



To obtain modulating operation, the RS/M BLU series of burners requires a regulator with three point outlet controls. The following table lists the accessories for modulating operation with their application range. For remote setpoint use RWF 55.

BURNER	TYPE	KIT CODE
► All models	RWF 50.2 - Basic version with 3 position output	20073595
	RWF 55.5 - Complete with RS-485 interface	20074441
	RWF 55.6 - Complete with RS-485/ PROFIBUS interface	20074442

PROBE



The relative temperature or pressure probes fitted to the power controller must be chosen on the basis of the application.

BURNER	TYPE	RANGE (°C) (BAR)	KIT CODE
► All models	Temperature PT 100	-100 ÷ 500°C	3010110
	Pressure 4 ÷ 20 mA	0 ÷ 2,5 bar	3010213
	Pressure 4 ÷ 20 mA	0 ÷ 16 bar	3010214
	Pressure 4 ÷ 20 mA	0 ÷ 25 bar	3090873

ANALOG CONTROL SIGNAL CONVERTER



BURNER	TYPE (INPUT SIGNAL)	KIT CODE
► RS 310-410-510-610/M	0/2 - 10 V (impedance 200 K Ω)	20074479
	0/4 - 20 mA (impedance 250 Ω)	

POTENTIOMETER

BURNER	KIT CODE
► RS 310-410-510-610/M	20074487

Continuous ventilation kit



If the burner requires continuous ventilation in the stages without flame, a special kit is available as given in the following table:

BURNER	KIT CODE
► RS 310-410-510-610/M	20074542

RS 310-410-510-610/M MZ SERIES

Burner accessories

PC interface kit



To connect the RMG control panel to a personal computer for the transmission of operation, fault signals and detailed service information, an interface adapter with PC software are available.

BURNER	KIT CODE
▶ RS 310-410-510-610/M	3002719

Sound proofing box

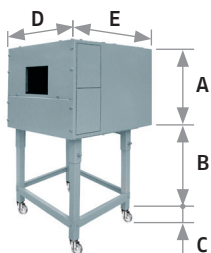

If noise emission needs reducing even further, sound-proofing boxes are available.

When a lower "B" dimension is required, it is available the Box Support Kit code 20065135 which allows to reduce it at the fixed dimension of 55 mm. The sound-proofing boxes are not suitable for outdoor use.

BURNER	BOX TYPE	A (mm)	B (mm) min. - max	C (mm)	D (mm)	E (mm)	[dB(A)] (*)	KIT CODE
▶ RS 310-410/M	C7	1255	160 - 980	110	1140	1345	10	3010376
▶ RS 610/M	C7 PLUS	1255	270 - 1090	110	1240	1345	10	20085111
▶ RS 310-410/M ▶ RS 510/M	C7	1255	165	110	1140	1345	10	20027778

(*) Average noise reduction according to EN 15036-1 standard

Spacer kit

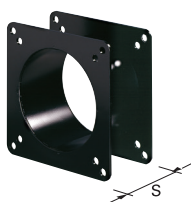

If burner head penetration into the combustion chamber needs reducing, varying thickness spacers are available, as given in the following table:

BURNER	Spacer thickness S (mm)	KIT CODE
▶ All models	180	20008903







Modulating Gas Burners

RS 310-410-510-610/M MZ SERIES

Gas train accessories

Adapters

In certain cases, an adapter must be fitted between the gas train and the burner, when the diameter of the gas train is different from the set diameter of the burner. Below are given the available adapters; please see on the Gas Train list the correct adapter codes to select.

ADAPTER	DIMENSIONS			ADAPTER CODE
	Ø1 DN	Ø2 DN	A mm	
1" 1/2  2"	-	-	65	20064220
2"  2"	-	-	65	20042324
DN 80  2" 1/2  2"	-	-	300	3000826
DN 100  DN 80	100	80	50	3010370
DN 80/65  2"	2"	65/80	780	20068062
	80	80	400	3010222
	100	80	400	3010223
	125	80	320	3010224

Seal control kit



To test the valve seals on the gas train, a special "seal control kit" is available. The valve seal control device is compulsory (EN 676) on gas trains to burners with a maximum output over 1200 kW. The seal control is type VPS 504.

GAS TRAIN	KIT CODE for 50 Hz operation
► MB type	3010123
► VGD 50/1	3010123+20186306
► VGD 65/1 - 80/1 - 100/1 - 125/1	3010123

Stabiliser spring



To vary the pressure range of the gas train stabilisers, accessory springs are available. The following table shows these accessories with their application range. Please refer to the technical manual for the correct choice of spring.

GAS TRAIN	SPRING COLOUR	SPRING PRESSURE RANGE mbar	SPRING CODE
► VGD/1 series	Neutral	0 - 22	20181839
	Yellow	15 - 120	20141900
	Red	100 - 250	20141901